

Chlorhexidine versus saline in reducing the risk of catheter associated urinary tract infection: A cost-effectiveness analysis



Brett G. Mitchell^{a,b,*}, Oyebola Fasugba^{c,d}, Allen C Cheng^{e,f}, Victoria Gregory^a, Jane Koerner^g, Peter Collignon^{h,i}, Anne Gardner^j, Nicholas Graves^k

^a Faculty of Arts, Nursing and Theology, Avondale College of Higher Education, 185 Fox Valley Road, Wahroonga, New South Wales 2076, Australia

^b School of Nursing and Midwifery, University of Newcastle, Newcastle, New South Wales, Australia

^c Nursing Research Institute, Australian Catholic University & St Vincent's Health Australia Sydney, New South Wales, Australia

^d Lifestyle Research Centre, Avondale College of Higher Education, Cooranbong, New South Wales, Australia

^e School of Public Health and Preventive Medicine, Monash University, Melbourne, Victoria, Australia

^f Infectious Prevention and Healthcare Epidemiology Unit, Alfred Hospital, Melbourne, Australia

^g School of Nursing, Midwifery and Paramedicine Australian Catholic University, Watson Australia

^h Australian Capital Territory Pathology, Canberra Hospital and Health Services, Yamba Drive, Garran, Australian Capital Territory 2605, Australia

ⁱ Medical School, Australian National University, Acton, Australian Capital Territory 2601, Australia

^j School of Public Health and Social Work, Queensland University of Technology, Brisbane, Queensland, Australia

^k Institute of Health and Biomedical Innovation, Queensland University of Technology, Brisbane, Australia

ARTICLE INFO

Article history:

Received 11 February 2019

Received in revised form 4 April 2019

Accepted 5 April 2019

Keywords:

Chlorhexidine
Cost-benefit analysis
Costs and cost analysis
Health services
Infection control
Nursing
Urinary catheters
Urinary tract infections

ABSTRACT

Background: Catheter associated urinary tract infections are one of the most common infections acquired in hospital. A recent randomised control study demonstrated the benefit of using chlorhexidine (0.1%) for meatal cleaning prior to urinary catheter insertion, by reducing both catheter associated asymptomatic bacteriuria and infection. These findings raise the important question of whether a decision to switch from saline to chlorhexidine was likely to be cost-effective. The aim of this paper was to evaluate the cost-effectiveness of adopting routine use of chlorhexidine for meatal cleaning prior to urinary catheter insertion

Methods: The outcomes of this cost-effectiveness study are changes to health service costs in \$AUD and changes to quality adjusted life years from a decision to adopt 0.1% chlorhexidine for meatal cleaning prior to urinary catheter insertion as compared to saline. Effectiveness outcomes for this study were taken from a 32 week stepped wedge randomised controlled study conducted in three Australian hospitals.

Results: The changes in health costs from switching from saline to 0.1% chlorhexidine per 100,000 catheterisations would save hospitals AUD\$387,909 per 100,000 catheterisations, prevent 70 cases of catheter associated urinary tract infections, release 282 bed days and provide a small improvement in health benefits of 1.43 quality adjusted life years. Using a maximum willingness to pay for a marginal quality adjusted life year threshold of AUD\$28,000 per 100,000 catheterisations, suggests that adopting chlorhexidine would be cost effective and potentially cost-saving.

Conclusion: The findings from our work provide evidence to health system administrators and those responsible for drafting catheter associated urinary tract infections prevention guidelines that investing in switching from saline to chlorhexidine is not only clinically effective but also a sensible decision in the context of allocating finite healthcare resources.

© 2019 The Author(s). Published by Elsevier Ltd. This is an open access article under the CC BY-NC-ND license (<http://creativecommons.org/licenses/by-nc-nd/4.0/>).

What is already known about the topic?

- Urinary tract infections are one of the most common infections patients acquire in hospital and are commonly associated with urinary catheter use.
- Approximately one in five hospitalised patients receive and indwelling urinary catheter.

* Corresponding author at: Avondale College, Clinical Education Centre, 185 Fox Valley Road, Wahroonga, New South Wales 2076, Australia.

E-mail address: brett.mitchell@avondale.edu.au (B.G. Mitchell).

- The use of chlorhexidine (0.1%) for meatal cleaning prior to urinary catheter insertion reduces the incidence of catheter associated asymptomatic bacteriuria and catheter associated urinary tract infection, compared to normal saline.

What this paper adds

- This research demonstrates that the use of chlorhexidine for meatal cleaning prior to urinary catheter insertion is cost-effective and potentially cost saving for health services.

1. Introduction

Point prevalence studies conducted in the United States and Europe show healthcare associated infections (HAI) pose a significant risk to hospitalised patients, with a point prevalence of between 4 and 6%. (European Centre for Disease Prevention and Control, 2013; Magill et al., 2014), In one study, urinary tract infection (UTI) accounted for approximately 16% of all HAIs, (European Centre for Disease Prevention and Control, 2013) and are commonly associated with indwelling catheter use. These infections are referred to as catheter associated urinary tract infections (CAUTIs). By prolonging a patient's length of hospital stay, increasing treatment costs and risk of antimicrobial resistance CAUTIs place an economic burden on patients and health services (Nicolle, 2014; Laxminarayan et al., 2013; Hollenbeak and Schilling, 2018).

Guidelines for the prevention and control of CAUTIs have been developed in many countries. (Loveday et al., 2014; Lo et al., 2014; National Health and Medical Research Council, 2010) Recommendations include minimising catheter use, using correct insertion practices, appropriate maintenance, surveillance of infections and prompt removal of urinary catheters. One element of correct insertion practices is cleaning of the urethral meatus prior to catheterisation. The concept of cleaning the meatal area is to reduce the risk of introducing bacteria during catheter insertion. Until recently, the best agent for meatal cleaning has been unclear, as evidence is low quality, (Fasugba et al., 2017a) and there is variation in clinical practice (Fasugba et al., 2017b).

Chlorhexidine (0.1%) and saline (0.9%) are two common agents used for meatal cleaning, with chlorhexidine being more expensive. With between 18 and 25% of patients admitted to hospital receiving a urinary catheter, (Gardner et al., 2014; Shackley et al., 2017), there is a strong case for establishing which agent is optimal. During 2017 and 2018, we conducted a randomised controlled trial in three Australian hospitals to determine the effectiveness and cost effectiveness of 0.1% chlorhexidine solution versus 0.9% saline. (Mitchell et al., 2017) The effectiveness outcomes demonstrated that chlorhexidine was more effective than saline, in reducing the incidence of catheter associated asymptomatic bacteriuria (CA-ASB), incident rate ratio 0.26 (95% CI 0.08–0.86, $p=0.026$) and CAUTI, incidence rate ratio 0.06 (95% CI 0.01–0.32, $p<0.001$). (Fasugba et al., 2018a).

This trial provided an opportunity to address the important question of whether a decision to switch from saline to the more expensive chlorhexidine during urinary catheter insertion was likely to be cost effective or even cost saving. Health services operate with scarce resources and should invest in innovations that make good economic sense. (Graves, 2004; Graves et al., 2007), In this paper, we present cost effectiveness outcomes, specifically, an evaluation of the cost effectiveness of adopting routine use of chlorhexidine for meatal cleaning prior to urinary catheter insertion. We examine changes to health service costs and

changes to quality adjusted life years (QALYs) from a decision to adopt 0.1% chlorhexidine.

2. Methods

The main outcomes of this cost-effectiveness study are changes to health service costs in \$AUD and changes to QALYs from a decision to adopt 0.1% chlorhexidine for meatal cleaning prior to urinary catheter insertion as compared to saline. Changes to these outcomes arose from the predicted change in the number of cases of CAUTI and blood stream infections secondary to CAUTIs. The intervention cost was defined as the additional cost of using chlorhexidine instead of saline for each hospitalised patient that had a urinary catheter. We developed a simple decision tree to evaluate cost effectiveness. We met the requirements of the Consolidated Health Economic Evaluation Reporting Standards statement. (Husereau et al., 2013) The trial is registered with the Australian New Zealand Clinical Trials Registry, approval number ACTRN 12617000373370.

2.1. Target population

The target population for this study, is hospitalised patients who received a urinary catheter during their hospital stay. Patients who were admitted to one of included hospitals and who received a urinary catheter during the study period were eligible for inclusion. Patients who received a urinary catheter were identified prospectively and followed-up during the trial period for seven days following catheter insertion. There were 1642 participants in the study, with 697 in the control group and 945 in the intervention group. The mean age was 62 (SD 23, median 69 years).

2.2. Setting and location

Effectiveness outcomes for this study were taken from a 32 week stepped wedge randomised controlled study. (Stewardson et al., 2014) The setting for the primary study was three Australian hospitals. The three hospitals were, a large tertiary referral hospital with approximately 85,000 admissions per year, a regional hospital servicing urban and rural areas with approximately 30,000 admissions per year and one of the largest private hospitals in Australia, with over 500 inpatient beds. Inclusion criteria for the primary study have been detailed in the study protocol (Mitchell et al., 2017).

2.3. Study perspective

The cost-effectiveness evaluation undertaken represents a societal perspective, and is therefore important for health resource allocation.

2.4. Comparators

The hospital wide intervention was the use of 0.1% chlorhexidine solution to clean the meatus prior to urinary catheterisation. Following a two-month control phase, in which 0.9% saline was used to clean the meatus before urinary catheterisation, one hospital transitioned to the intervention every two months.

2.5. Time horizon

The time horizon in this study was from the point of urinary catheterisation, until infection resolution (including death).

2.6. Discount rate

A discounting of 3% was applied for health outcomes.

2.7. Choice of health outcomes

The outcomes for the cost-effectiveness analysis were CAUTI and blood stream infection secondary to a CAUTI. These are patient based outcomes.

2.8. Choice of model - model structure

The model shown in Fig. 1 was based on the following assumptions: patients faced a probability of asymptomatic bacteriuria, marked as BACT; if positive they faced a probability of CAUTI; if positive they finally faced a probability of acquiring a blood stream infection secondary to a CAUTI, marked BSI. Patients would then either live or die. Estimated values for both costs and health outcomes in QALYS were used to populate the terminal nodes, marked as triangles, for each branch, and the model was rolled back from right to left such that the expected value of costs and QALYS were summarised for both 0.9% saline and 0.1% chlorhexidine as per the primary study. (Mitchell et al., 2017)

2.9. Measurement of effectiveness - event probabilities

The probabilities of a hospitalised patient having asymptomatic bacteriuria or a CAUTI up to 7 days following urinary catheter insertion, when using 0.1% chlorhexidine and 0.9% saline, were derived from our previous work and is reproduced in Table 1 (Mitchell et al., 2017). The probability of a patient with a CAUTI acquiring a blood stream infection secondary to a CAUTI was derived from the literature (Tambyah and Maki, 2000). The probability of death following a bloodstream infection was based on data from *Escherichia coli* bloodstream infections, given that this organism is the most commonly implicated in UTIs. (Laupland et al., 2008)

2.10. Measurement and valuation of outcomes - valuation and duration of health states

Health utilities represent the value of the quality of life of participants on a scale of 1 (perfect health) to 0 (dead). (Brazier et al., 2014) Australian baseline values, a utility decrement for UTI and the utility state for an intensive care unit (ICU) admission were taken from the literature and used to update the decision tree model, see Table 2. (Clemens et al., 2014; van den Hout et al., 2014) The utility decrement for a bloodstream infection was estimated by deducting the utility for an ICU admission from the Australian normal value. We assumed the mean age of the at risk population

was 62 years based on data sourced from a randomised controlled study that prospectively observed the incidence of catheterisation in one hospital. [Fasugba et al., 2018b] The life expectancy of patients was based on life tables for males and females born between 1953 and 1955. [Australian Bureau of Statistics, 2018]

2.11. Estimating resources and costs - costs, bed days released and their values

The product costs of saline and chlorhexidine were derived from the average of the prices paid by each of the participating hospitals. The costs for chlorhexidine were AUD\$63.50 per box of 30 (Hospital A), AUD\$67.00 per box of 30 (Hospital B) and AUD \$65.50 per box of 30 (Hospital C). Saline costs were AUD\$37.80 and AUD\$39.56 per box of 30 in Hospital A and Hospital B, respectively. No costs were readily available for Hospital C. The average increase in cost to switch from saline to chlorhexidine was AUD\$0.88 per ampoule. To calculate antimicrobial therapy costs, we assigned a value of AUD\$19.22 for an episode of CAUTI to account for 5 days of amoxicillin/clavulanic acid treatment. We assigned a cost of AUD \$41.84 for a bloodstream infection to represent the cost of 1 g cefazolin IV for 2 days, followed by oral administration for 5 days. (Department of Health, 2018; Daneman et al., 2011), The substitution of saline with chlorhexidine presented no additional staffing time or costs. We did not include costs associated with CA-ASB or laboratory costs.

A prevented CAUTI was estimated to release 4 bed days (mean 4, SD 0.48). This estimate came from an Australian study that used a multi-state model to estimate excess length of stay and mortality associated with healthcare-associated UTIs. (Mitchell et al., 2016) The method of moments was used to fit a Gamma distribution (Gamma 68.11, 0.06) for this parameter, which was appropriate for the skew typical for length of stay data. Preventing a blood stream infection associated with a CAUTI was estimated to release 15 days (mean 15.53, SD 8.96). Primary data were provided on the duration of antimicrobial treatment for 198 patients with bacteraemia caused by a CAUTI. This retrospective cohort study was undertaken in 14 ICUs across Canada (Daneman et al., 2016). The method of moments was used to fit a Gamma distribution (Gamma 3.01, 5.17) for this parameter. We assumed that one-third of the days released would have been spent in the ICU.

Monetary values for bed days were derived using two competing methods. The first was an accounting method that divided total recurrent expenditure on admitted care (Australian Institute of Health and Welfare, 2017a) by the total number of patient days in Australian public hospitals in 2015–16. (Australian Institute of Health and Welfare, 2017a, b), This rendered estimates of AUD\$6280 for an ICU bed day and AUD\$1667 for a ward bed day. The second method was to update 2016 costs taken from the findings of a contingent valuation study of Australian hospital chief

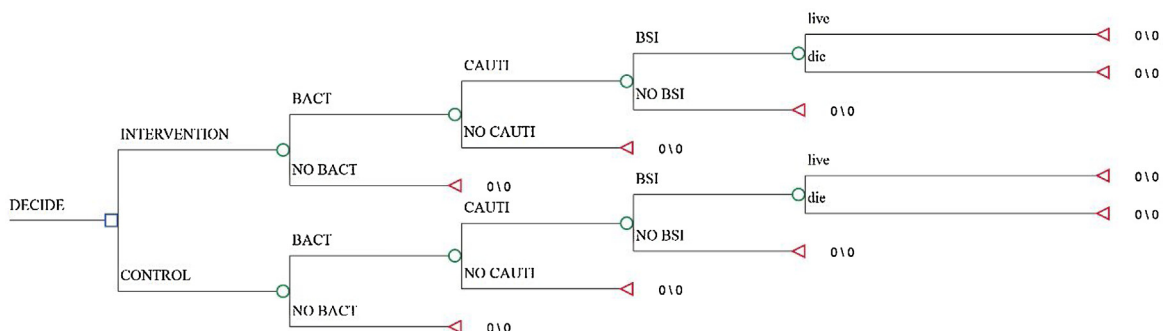

Fig. 1. Decision tree for cost-effectiveness model.

Table 1
Probabilities of events in model.

Parameter	Prior Distribution	Mean	Source
Probability Bacteriuria – CONTROL	Beta(29,668)	0.042	Fasugba et al. (2019)
Probability Bacteriuria – INTERVENTION	Beta(16,929)	0.017	Fasugba et al. (2019)
Probability CAUTI – CONTROL	Beta(13,684)	0.019	Fasugba et al. (2019)
Probability CAUTI – INTERVENTION	Beta(4941)	0.0042	Fasugba et al. (2019)
Probability of death from bloodstream infection	Beta(2,301,811)	0.11	Laupland et al. (2008)
Probability bloodstream infection from a CAUTI	Beta(1234)	0.0043	Tambyah and Maki (2000)

Note: CAUTI = Catheter associated urinary tract infection.

Table 2
Health Outcomes.

Parameter	Prior Distribution	Mean	Source
Utility Australian norm	Beta (7,354,162)	0.85	Clemens et al. (2014)
Utility decrement for UTI	Beta (6156)	0.04	van den Hou et al. (2014)
Utility for ICU admission	Beta (1,370,71)	0.66	Warren et al. (2004)
Age for at risk population	Normal (6217)	62	Fasugba et al. (2018)

Note: UTI = urinary tract infection. ICU = Intensive care unit.

executive officers, (Page et al., 2017) which revealed their willingness to pay for bed days released by an infection prevention programme. Values of AUD\$284 and AUD\$573 for a ward and ICU bed day were used, respectively. Competing results are presented for ‘accounting costs’ and the willingness to pay for bed days, marked as ‘WTP’

2.12. Currency, price date, and conversion

All cost data were collected and analysis using Australian dollars. Costs taken from the literature were also presented in Australian dollars. No currency conversions were necessary.

2.13. Analytical methods - model evaluation

The main outcomes were the total costs and QALYs associated with a decision to adopt the use of chlorhexidine over saline. To propagate forward the uncertainty in the models’ parameters, 5000 simulations were taken randomly and the results recorded. The probability that adopting chlorhexidine was a cost-effective decision was shown by the proportion of these 5000 resamples that were returned below a threshold value of 28,000 per QALY gained. (Edney et al., 2018) Discounting was applied for health outcomes that arose in time periods >12 months.

3. Results

The changes in health costs from switching from saline to 0.1% chlorhexidine per 100,000 catheterisations are presented in

Table 3
Results of sampling from model parameters.

Per 100,000 patients catheterised	Mean	Min	Max
Change to total costs (Accounting costs)	-\$387,909	-\$1,443,740	\$70,697
Change to total costs (WTP costs)	\$6299	-\$237,102	\$91,537
Change to QALYS	1.43	-0.17	5.72
Cost of intervention	\$89,012	\$81,000	\$97,000
Number asymptomatic Bacteriuria prevented	2450.60	-539.58	6369.21
Number of CAUTI prevented	69.96	2.16	222.80
Number of bloodstream infections prevented	0.30	0.00	3.84
Ward bed days released	282.40	7.87	885.12
ICU bed days released	1.52	0.00	28.37

Table 3. On average, the change to chlorhexidine would save AUD\$387,909 per 100,000 catherisations using an accounting model and a cost increase of AUD\$6299 using a willingness to pay method. The use of chlorhexidine was estimated to prevent 70 cases of CAUTI and release 282 bed days. There was a small improvement in health benefits of 1.43 QALYs.

The joint distribution of change to total costs and change to QALYS for two scenarios, one using accounting methods and one using willingness to pay methods is shown in Fig. 2. A maximum willingness to pay for a marginal QALY threshold of AUD\$28,000 per 100,000 catherisations was applied. (Edney et al., 2018) Using an accounting method, all distribution (100%) was below the x-axis, indicating a 100% probability that an adoption decision would be cost saving. A decision to switch to chlorhexidine dominated a decision to remain with saline. Using the willingness to pay approach, 75% of simulations were below the QALY threshold, and 36% were below the x-axis. In this instance, there was a 75% probability that an adoption decision would be cost effective and a 36% probability it would be cost saving.

4. Discussion

We estimated the change in health service costs and QALYs associated with using 0.1% chlorhexidine for meatal cleaning prior to urinary catheter insertion. We found that adopting 0.1% chlorhexidine was likely to be a cost-effective intervention with the potential for being cost-saving. In our analysis, we used conservative cost estimates for bed days released and modelled two approaches to provide transparent and flexible information for decision makers. The implementation of chlorhexidine provided some small improvement in QALYs.

In our primary study, we showed that 0.1% chlorhexidine was associated with a reduction in CA-ASB and CAUTI of 94%. (Fasugba et al., 2018a) Given the frequency of urinary catheterisation for hospital patients and the higher costs of using chlorhexidine compared to saline, evaluating the cost effectiveness of switching from saline to chlorhexidine is important for decision makers. Our analysis suggested that by switching to chlorhexidine, for every 100,000 catheterisations, a hospital has the potential to reduce costs by AUD\$387,000 and free up 282 bed days. Our results can be applied to any context where the prevalence of urinary catheterisation and number of patient admissions are known. For example, in Australia, based on 3.06 million overnight admissions to public hospitals (2016–17) (Australian Institute of Health and Welfare, 2018) and 25% (765,000) of patients receiving a catheter (Gardner et al., 2014), a switch from saline to chlorhexidine could result in AUD\$2.9 million of savings to the public hospital health budget, releasing 2160 bed days. These data support a change in local and national policy, as well as clinical guidelines to support the use of 0.1% chlorhexidine for meatal cleaning prior to urinary catheterisation.

Challenges in cost-effectiveness analysis include determining the value of a hospital bed and the threshold for the additional cost imposed on the system for one additional QALY. We used a

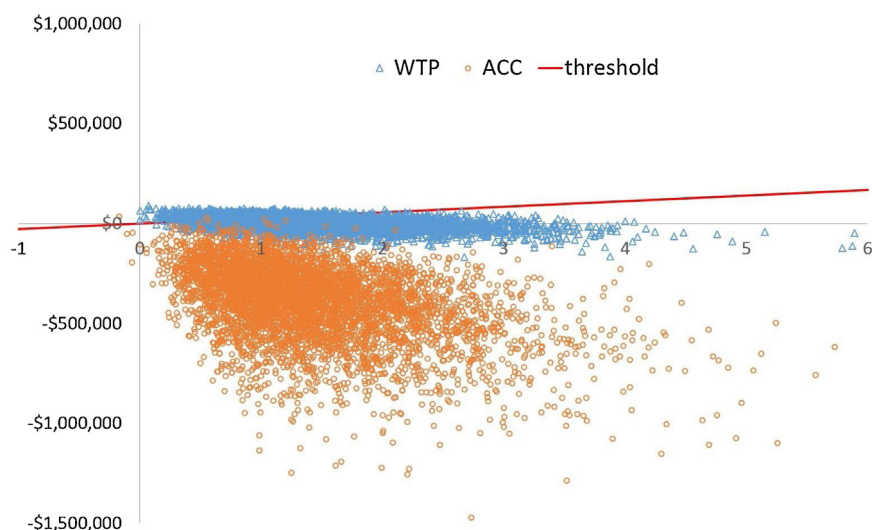

Fig. 2. Joint distribution of change to total costs and change to QALYS from the adoption of chlorhexidine 0.1%.

Note: The figure represents two scenarios: bed days valued by accounting methods (dots) and by willingness to pay methods (triangles). The red line indicates a maximum willingness to pay for a marginal QALY threshold of \$28,000.

figure of AUD\$28,000 per QALY gained. (Mitchell et al., 2017) Cost-effectiveness analysis in the United States has traditionally used USD 50,000 per QALY, with arguments suggesting that this figure should be higher (Neumann et al., 2014). In the United Kingdom, an analysis of primary care trust spending suggested that the probability that the threshold would be less than GBP 20,000 per QALY was 0.89, and the probability that it would be less than GBP 30,000 per QALY was 0.97 (Claxton et al., 2015). The costs saved by preventing an infection are largely generated by a reduction in treatment cost and the value of releasing a bed day. A common method for determining the value of bed days released uses accounting methods to estimate the average amount of money allocated to produce bed days. However, this method does not consider the fact that many costs in hospitals, such as salaries and overheads, are fixed and cannot be recovered (Graves, 2018). For this reason, it has been argued that to calculate the value of a released bed day, a willingness to pay model should be used. This model values bed days according to how much chief executive officers would be willing to pay to release them. (Stewardson et al., 2014; Page et al., 2017). The monetary values estimated using this method are considerably less than those derived using accounting methods. In our study, we used both accounting and willingness to pay approaches. In addition, we used a conservative threshold to estimate the value of an additional QALY. Regardless of approach, we showed a convincing probability that adopting chlorhexidine would be cost effective (72% using a willingness to pay model) and cost saving (100% using an accounting model, 35% using a willingness to pay model).

Our cost-effectiveness evaluation had several strengths. Our probability estimates for the effect of the intervention were based on robust data from a multi-centred pragmatic clinical trial. (Fasugba et al., 2018b) To estimate the length of stay associated with contracting a CAUTI, we used data from a study that used appropriate statistical methods (Mitchell et al., 2016). A recent systematic review evaluating the treatment costs of CAUTI suggested that it carries an attributable cost of USD 876 per case for diagnostic tests and medications. Rather than relying on estimates and to ensure that our analysis was conservative, we included only antimicrobial treatment costs and no laboratory costs. Treatment costs in our study were AUD \$19.22 for a case of CAUTI. In our primary study, we

demonstrated that using chlorhexidine 0.1% was associated with a 74% reduction in CA-ASB (Fasugba et al., 2018a). In many instances, CA-ASB treatment involves the use of antimicrobials, thus a reduction in CA-ASB would lead to further cost savings and benefits associated with a reduction in overall antimicrobial consumption. Our study modelled the cost effectiveness of chlorhexidine 0.1% in reducing CAUTI and did not consider the added benefit of a reduction in costs associated with treating CA-ASB. A limitation of our study was its reliance on relatively old estimates for the probability of blood stream infection secondary to CAUTIs and only 2 days of IV therapy with antibiotics.

We have previously demonstrated the clinical efficacy of using 0.1% chlorhexidine to reduce the risk of CA-ASB and CAUTI. (Fasugba et al., 2018a) However, improving patient outcomes is only one element of high value healthcare, and reducing per capita cost is also important (Berwick et al., 2008). The findings from our work provide clear evidence to health system administrators and those responsible for drafting CAUTI prevention guidelines that investing in switching from saline to chlorhexidine is not only clinically effective but also a sensible decision in the context of allocating finite healthcare resources.

Ethics

This trial was approved by the Avondale College of Higher Education Human Research Ethics Committee (HREC) (approval number 2017:03), the Australian Capital Territory Health HREC (approval number ETH-4-17-083) and the Adventist HealthCare Limited HREC (approval number 2017–018). A waiver of individual patient consent obtained from the HRECs. Ethics and site specific approvals took approximately eight months to obtain.

Contributors

All authors designed the study. BM is the Chief Investigator for the study. BM and VG were responsible for study administration and management, and all authors were involved in ongoing implementation. NG analysed the data. BM and NG wrote the first draft of the manuscript. All authors interpreted the data. All authors revised it critically for important intellectual content. All authors read and approved the final manuscript.

Funding

HCF Foundation.

Declaration of interests

We declare no competing interests.

Acknowledgements

This study was funded by a competitive grant awarded by the HCF Foundation. Cash support from Avondale College of Higher Education was also provided. The funders played no role at all in the conduct of the study or in any element of the manuscript preparation.

References

- Australian Bureau of Statistics, 2018. Life Tables, States, Territories and Australia, 2015–2017. 3302.0.55.001 Ed. Australian Bureau of Statistics, Canberra.
- Australian Institute of Health and Welfare, 2017a. Hospital Resources 2015–16: Australian Hospital Statistics. Health Services Series no. 78. Cat. No. HSE 190. Australian Institute of Health and Welfare, Canberra.
- Australian Institute of Health and Welfare, 2017b. Admitted Patient Care 2015–16: Australian Hospital Statistics. Health Services Series no.75. Cat. No. HSE 185. Australian Institute of Health and Welfare, Canberra.
- Australian Institute of Health and Welfare, 2018. Admitted Patient Care 2016–17: Australian Hospital Statistics. Health Services Series no.84. Cat. No. HSE 201. Australian Institute of Health and Welfare, Canberra.
- Berwick, D.M., Nolan, T.W., Whittington, J., 2008. The triple aim: care, health, and cost. *Health Aff. (Millwood)* 27 (3), 759–769.
- Brazier, J., Connell, J., Papaioannou, D., et al., 2014. A systematic review, psychometric analysis and qualitative assessment of generic preference-based measures of health in mental health populations and the estimation of mapping functions from widely used specific measures. *J. Health Technol. Assess.* 18 (34), vii.
- Claxton, K., Martin, S., Soares, M., et al., 2015. Methods for the estimation of the national institute for health and care excellence cost-effectiveness threshold. *Health Technol. Assess.* 19 (14), 1.
- Clemens, S., Begum, N., Harper, C., et al., 2014. A comparison of EQ-5D-3L population norms in Queensland, Australia, estimated using utility value sets from Australia, the UK and USA. *Qual. Life Res.* 23 (8), 2375–2381.
- Daneman, N., Shore, K., Pinto, R., et al., 2011. Antibiotic treatment duration for bloodstream infections in critically ill patients: a national survey of Canadian infectious diseases and critical care specialists. *Int. J. Antimicrob. Agents* 38 (6), 480–485.
- Daneman, N., Rishu, A.H., Xiong, W., et al., 2016. Duration of antimicrobial treatment for bacteremia in Canadian critically ill patients. *Crit. Care Med.* 44 (2), 256–264.
- Department of Health, 2018. Pharmaceutical Benefits Scheme. Australian Government, Canberra.
- Edney, L.C., Haji Ali Afzali, H., Cheng, T.C., et al., 2018. Estimating the reference incremental cost-effectiveness ratio for the Australian health system. *Pharmacoeconomics* 36 (2), 239–252.
- European Centre for Disease Prevention and Control, 2013. Point Prevalence Survey of Healthcare-associated Infections and Antimicrobial Use in European Acute Care Hospitals. European Centre for Disease Prevention and Control, Stockholm.
- Fasugba, O., Koerner, J., Mitchell, B.G., et al., 2017a. Systematic review and meta-analysis of the effectiveness of antiseptic agents for meatal cleaning in the prevention of catheter-associated urinary tract infections. *J. Hosp. Infect.* 95 (3), 233–242.
- Fasugba, O., Koerner, J., Mitchell, B.G., et al., 2017b. Meatal cleaning with antiseptics for the prevention of catheter-associated urinary tract infections: a discussion paper. *Infect. Dis. Health* 22 (3), 136–143.
- Fasugba, O., Cheng, A.C., Gregory, V., Graves, N., Koerner, J., Collignon, P., Mitchell, B.G., Gardner, A., 2019. Chlorhexidine for meatal cleaning in reducing catheter-associated urinary tract infections: a multicentre stepped-wedge randomised controlled trial. *The Lancet Infect. Dis.*
- Fasugba, O., Cheng, A.C., Russo, P.L., et al., 2018b. Reducing urinary catheter use: a protocol for a mixed methods evaluation of an electronic reminder system in hospitalised patients in Australia. *BMJ Open* 8 (5), e020469.
- Gardner, A., Mitchell, B.G., Beckingham, W., et al., 2014. A point prevalence cross-sectional study of healthcare-associated urinary tract infections in six Australian hospitals. *BMJ Open* 4 (7) .
- Graves, N., 2004. Economics and preventing hospital-acquired infection. *Emerg. Infect. Dis.* 10 (4), 561.
- Graves, N., 2018. Make economics your friend. *J. Hosp. Infect.* 100 (2), 123–129.
- Graves, N., Weinhold, D., Tong, E., et al., 2007. Effect of healthcare-acquired infection on length of hospital stay and cost. *Infect. Control Hosp. Epidemiol.* 28 (3), 280–292.
- Hollenbeak, C.S., Schilling, A.L., 2018. The attributable cost of catheter-associated urinary tract infections in the United States: a systematic review. *Am. J. Infect. Control* 46 (7), 751–757.
- Husereau, D., Drummond, M., Petrou, S., et al., 2013. Consolidated health economic evaluation reporting standards (CHEERS) statement. *Value Health* 16 (2), e1–5.
- Laupland, K.B., Gregson, D.B., Church, D.L., et al., 2008. Incidence, risk factors and outcomes of *Escherichia coli* bloodstream infections in a large Canadian region. *Clin. Microbiol. Infect.* 14 (11), 1041–1047.
- Laxminarayan, R., Duse, A., Wattal, C., et al., 2013. Antibiotic resistance—the need for global solutions. *Lancet Infect. Dis.* 13 (12), 1057–1098.
- Lo, E., Nicolle, L.E., Coffin, S.E., et al., 2014. Strategies to prevent catheter-associated urinary tract infections in acute care hospitals: 2014 update. *Infect. Control Hosp. Epidemiol.* 35 (5), 464–479.
- Loveday, H., Wilson, J., Pratt, R., et al., 2014. epic3: national evidence-based guidelines for preventing healthcare-associated infections in NHS hospitals in England. *J. Hosp. Infect.* 86, S1–S70.
- Magill, S.S., Edwards, J.R., Bamberg, W., et al., 2014. Multistate point-prevalence survey of health care-associated infections. *N. Engl. J. Med.* 370 (13), 1198–1208.
- Mitchell, B.G., Ferguson, J.K., Anderson, M., et al., 2016. Length of stay and mortality associated with healthcare-associated urinary tract infections: a multi-state model. *J. Hosp. Infect.* 93 (1), 92–99.
- Mitchell, B.G., Fasugba, O., Gardner, A., et al., 2017. Reducing catheter-associated urinary tract infections in hospitals: study protocol for a multi-site randomised controlled study. *BMJ Open* 7 (11), e018871.
- National Health and Medical Research Council, 2010. Australian Guidelines for the Prevention and Control of Infection in Healthcare (2010). National Health and Medical Research Council, Canberra.
- Neumann, P.J., Cohen, J.T., Weinstein, M.C., 2014. Updating cost-effectiveness—the curious resilience of the \$50,000-per-QALY threshold. *N. Engl. J. Med.* 371 (9), 796–797.
- Nicolle, L.E., 2014. Catheter associated urinary tract infections. *Antimicrob. Resist. Infect. Control* 3 (1), 23.
- Page, K., Barnett, A.G., Graves, N., 2017. What is a hospital bed day worth? A contingent valuation study of hospital chief executive officers. *BMC Health Serv. Res.* 17 (1), 137.
- Shackley, D.C., Whytock, C., Parry, G., et al., 2017. Variation in the prevalence of urinary catheters: a profile of National Health Service patients in England. *BMJ Open* 7 (6) e013842.
- Stewardson, A.J., Harbarth, S., Graves, N., 2014. Valuation of hospital bed-days released by infection control programs: a comparison of methods. *Infect. Control Hosp. Epidemiol.* 35 (10), 1294–1297.
- Tambyah, P.A., Maki, D.G., 2000. Catheter-associated urinary tract infection is rarely symptomatic: a prospective study of 1,497 catheterized patients. *Arch. Intern. Med.* 160 (5), 678–682.
- van den Hout, W.B., Caljouw, M.A., Putter, H., et al., 2014. Cost-effectiveness of cranberry capsules to prevent urinary tract infection in long-term care facilities: economic evaluation with a randomized controlled trial. *J. Am. Geriatr. Soc.* 62 (1), 111–116.
- Warren, D.K., Zack, J.E., Mayfield, J.L., et al., 2004. The effect of an education program on the incidence of central venous catheter-associated bloodstream infection in a medical ICU. *Chest* 126 (5), 1612–1618.