

## Symmetry and Measuring: Ways to Teach the Foundations of Mathematics Inspired by Yupiaq Elders

Jerry Lipka

*University of Alaska Fairbanks*

Barbara Adams

*University of Alaska Fairbanks*

Monica Wong

*Australian Catholic University*

David Koester

*University of Alaska Fairbanks*

Karen Francois

*Vrije Universiteit Brussel - Free University Brussels*

Follow this and additional works at: <https://scholarship.claremont.edu/jhm>



Part of the [Anthropology Commons](#), [Indigenous Education Commons](#), [Logic and Foundations of Mathematics Commons](#), [Mathematics Commons](#), and the [Science and Mathematics Education Commons](#)

---

### Recommended Citation

Lipka, J. Adams, B. Wong, M. Koester, D. and Francois, K. "Symmetry and Measuring: Ways to Teach the Foundations of Mathematics Inspired by Yupiaq Elders," *Journal of Humanistic Mathematics*, Volume 9 Issue 1 (January 2019), pages 107-157. DOI: 10.5642/jhummath.201901.07 . Available at: <https://scholarship.claremont.edu/jhm/vol9/iss1/7>

©2019 by the authors. This work is licensed under a Creative Commons License.

JHM is an open access bi-annual journal sponsored by the Claremont Center for the Mathematical Sciences and published by the Claremont Colleges Library | ISSN 2159-8118 | <http://scholarship.claremont.edu/jhm/>

The editorial staff of JHM works hard to make sure the scholarship disseminated in JHM is accurate and upholds professional ethical guidelines. However the views and opinions expressed in each published manuscript belong exclusively to the individual contributor(s). The publisher and the editors do not endorse or accept responsibility for them. See <https://scholarship.claremont.edu/jhm/policies.html> for more information.

---

## Symmetry and Measuring: Ways to Teach the Foundations of Mathematics Inspired by Yupiaq Elders

### Cover Page Footnote

This work has been generously supported by a grant from the National Science Foundation, Anna Kerttula program officer, Arctic Social Sciences division. The grant entitled The Potential Contribution of Indigenous Knowledge to Teaching and Learning Mathematics, was funded from 2012-2018 (grant number 1203194). However, any opinions, findings, and conclusions or recommendations expressed in this material are those of the authors and do not necessarily reflect the views of the National Science Foundation. We acknowledge the enduring steadfast support and tireless work of the Yupiaq practitioner scholars and educators. We name Raphael and Vivian Jimmy and in particular Raphael's major contribution in identifying qukaq (the center of everything). This was accomplished in a collegial environment with Anuska Nanalook, Anecia and Mike Toyukak providing multiple examples of the importance of the center and symmetry in everyday activity. Walkie Charles provided linguistic insights and creativity along with Eva Evelyn Yanez who moved from participant to co-leader in connecting the dots assisted by Sassa Peterson. Dora Andrew-Ihrke provided countless examples and demonstrations to make this seemingly invisible concept abundantly clear. Evelyn, Sassa, Walkie, and Dora switched from Yup'ik to English taking concepts from the non Yupiaq scholars and from the Yupiaq practitioner scholars into a meaningful context. We also acknowledge the contributions of practitioner scholars from the Carolinian Islands in particular Cal Hachibma, Yap State Department of Education, Miuty Nokar, Chuuk State Department of Education, Ali Haleyalur a master navigator, Yap Traditional Navigation Society. Knowledge shared between the Yupiaq and Carolinian Islanders strengthened the case for the importance of symmetry, measuring, and center as both groups realized that these concepts were hiding in plain sight. The Carolinian examples strengthened this work. We wish to acknowledge Victor Zinger, University of Alaska Fairbanks, Judy and Mel Olson, both retired from the University of Hawaii, Manoa for their stimulating discussions and work associated with this project, which helped us see mathematical and pedagogical connections to the concepts of symmetry, measuring, and center. Lastly, we acknowledge the work of our core staff Amy Topkok, project manager; Jumiah Johnson, for graphics; Keely Colby, for graphics and page layout; as well as Dixon Jones, for graphics, and Fran Pedersen for editing and proofing.

Symmetry and Measuring:  
Ways to Teach the Foundations of Mathematics  
Inspired by Yupiaq Elders

Jerry Lipka

*School of Education, University of Alaska Fairbanks, USA*  
jmlipka@alaska.edu

Barbara Adams

*School of Education, University of Alaska Fairbanks, USA*  
barbara.adams@alaska.edu

Monica Wong

*School of Education, Australian Catholic University, Strathfield, AUSTRALIA*  
monica.wong@acu.edu.au

David Koester

*Department of Anthropology, University of Alaska Fairbanks, USA*  
dckoester@alaska.edu

Karen François

*Department of Philosophy, Vrije Universiteit Brussel, BELGIUM*  
Karen.Francois@vub.be

---

**Abstract**

Evident in human prehistory and across immense cultural variation in human activities, symmetry has been perceived and utilized as an integrative and guiding principle. In our long-term collaborative work with Indigenous Knowledge holders, particularly Yupiaq Eskimos of Alaska and Carolinian Islanders in Micronesia,

we were struck by the centrality of symmetry and measuring as a comparison-of-quantities, and the practical and conceptual role of *qukaq* [center] and *ayagneq* [a place to begin]. They applied fundamental mathematical principles associated with symmetry and measuring in their everyday activities and in making artifacts. Inspired by their example, this paper explores the question: Could symmetry and measuring provide a systematic and integrative way to teach the foundations of mathematical thinking? We illustrate how the fundamental structures of symmetry, measuring, and comparison-of-quantities, starting with the embodied orthogonal axes, form a basis for properties of equality, aspects of numbers and operations (including place value), geometry and number line representations, functions, algebraic reasoning, and measurement. We conclude by embedding the earlier geometric constructions of triangles and squares within the unit circle and making explicit connections to trigonometric functions.

---

## 1. Introduction: The Fundamental Nature of Symmetry

Symmetry is ubiquitous, connecting art and function, practicality with aesthetics, and nature to mathematics. As a practical principle, symmetry underlies ways of perceiving, thinking, acting, and creating in the world. Its utility and the recognition of its beauty can be seen in symmetrically crafted tools found in archaeological sites dating back 1.4 million years [63] and in stunning artwork from Minoan culture dating around 1800-1600 BC (e.g., the golden bee pendant).<sup>1</sup> It appears in mosaics, buildings, and patterns across diverse cultures, across geographic regions and historic time periods [59, 30]. Symmetry has been analogously recognized as an overarching schema in the organization of social groups [17, 21, 35], and such symmetric relationships have been symbolically represented in practical objects such as weavings and in the physical organization of communities [46, 47]. Washburn [58] notes

---

<sup>1</sup>A personal observation made by co-author Karen François on a recent trip to Crete and the Heraklion Museum, images can be found at <https://www.ancient.eu/image/885/minoan-bee-pendant/?>, last accessed on January 2019. Bilateral symmetry has been observed since the ancient practices of arts and mathematics and in this example a millennium earlier than the ancient Greek philosopher mathematicians. The bee pendant (a gold ornament from Malia, Crete, consisting of two bees depositing a drop of honey in their honeycomb) dating from 1800-1700 B.C. is a nice example of bilateral symmetry in the arts.

how symmetric properties (measurement and positional relationships) are expressed in multidimensional ways in widely varying cultural artifacts, from the radial layout of a Navajo hogan to the symmetrical designs of a Persian carpet to repeating symmetric patterns.

This paper has been deeply informed by our long-term ethnographic and collaborative research with Yupiaq Eskimo knowledge holders and their systematic use of symmetry and measuring across a wide array of activities.<sup>2</sup> The culturally specific insights gained from over thirty years of working with Yupiaq elders and educators, and more recently knowledge holders from the Caroline Islands in Micronesia, allowed us to see how symmetry and measuring act as an underlying cultural code connecting a wide array of activities and systematizing epistemologies [38, 62]. Yet, the geometrical principles, for example, reflections creating equal distances from the center across a line of symmetry, that they employ transcend their cultural groups and can be applied widely to education. On the basis of numerous practical examples, we began to see how an analogous way of thinking about symmetry could be used as a fundamental framework for teaching school mathematics. We used these underlying mathematical principles to model how these processes can be cohesively applied to teach numbers, geometry, measuring, and early algebraic thinking. The elders' potential contribution to the learning and understanding of mathematics is their view of symmetry and measuring as a centerpiece, an integrative, creative, and constructive process. Even in situations in which symmetry does not exist, Yupiaq individuals visualize symmetry-asymmetry in a dynamic way. They turn asymmetries into symmetries, a way of perceiving and thinking that is similarly expressed in Navajo cosmology [62]. In practical activity, this approach reveals underlying arithmetic and algebraic structures. The systemic and creative ways in which the Yupiaq have used symmetry has helped to reveal the central

---

<sup>2</sup>Most of the authors have collaborated with Yupiaq elders and Carolinian Island knowledge holders for the past five years through a National Science Foundation, Arctic Social Sciences Division, from 2013 to 2018. Lipka has worked with Yupiaq teachers and elders from 1981 to the present. Lipka and Adams collaborated with elders, Yupiaq teachers/knowledge holders, through a series of grants that supported a program known as "Math in a Cultural Context" that developed supplemental elementary school curriculum, provided professional development, and conducted qualitative and quantitative studies. Evelyn Yanez, Dora Andrew-Ihrke, and Sassa Peterson are all Yupiaq teacher researchers, long-term colleagues, and "family" over these many years.

role that symmetry can have in school mathematics. These ways of thinking and actions on material embed the four basic arithmetic operations as they construct artifacts out of irregular and uneven raw material. This is in juxtaposition to the predominantly static way that symmetry is used in school mathematics, which typically relegates the topic to the margins, using it as an object to be identified, located, or sorted rather than a dynamic concept and generative process. Even in the Common Core State Mathematics Standards, symmetry is found only under the strand of Geometry and limited to locating, identifying, and decomposing and composing geometrical shapes [13], with no hint of the cohesive and generative nature of symmetry recognized by mathematicians, physicists, and anthropologists (among others) [19, 41, 58, 61].

Yupiaq activity, perception, and thought ground the abstract notions of symmetry, making the concept accessible, and cohesive for learning mathematics. Embedded in Yupiaq constructions are mathematical principles that harken back to the etymology of symmetry, “coming from the Greek *sym* and *metria*, which translates into the same measure” [40, page 3] and fundamentally connects symmetry, ratio, and proportions based in measurement [45, pages 90–92]. Like the ancients, the Yupiaq use symmetry as a generative and constructive process, including ratio relationships, scaling projects, and physical proof to ensure that their design and products maintain their proportions and aesthetic value. They often do this in a non-numeric environment, using a comparison-of-quantities approach which lends itself to algebraic thinking and representations on a geometric number line, as similarly noted by Davydov [15] and Bass [7].

### *1.1. Mathematical basis of symmetry*

More generally, symmetry is a central mathematical concept from the beginning of the practice of mathematics. It was discussed and used in mathematics and mathematical practices to interpret numbers and to give esthetic value to mathematical objects, connecting art and mathematics. Bilateral symmetry (or the symmetry of left and right) appears as the first case of a geometric concept that refers to the operation of reflection and rotation. Weyl also mentions that this kind of symmetry reflects the structure of the human body [60, page 8]. He describes the progression of the concept of symmetry from a vague notion of “harmony of proportions,” to the mathe-

mathematical concept of geometry in all its variation to a definition “the invariance of a configuration of elements under a group of automorphic transformations” [60, page *i*].

Yaglom [64] describes the modern development of symmetry and its profound influence on advances in mathematics. He notes Felix Klein’s contribution to and definition of geometry (and in collaboration with Sophus Lie), as “the science which studies the properties of figures preserved under the transformations of a certain group of transformations” [64, page 115]. Similarly, Trkowska [54] explains “the theory that studies the properties of figures preserved under all transformations of a given group is called the geometry of this group.” Klein and Lie’s work on groups, transformations, and invariance [64, 28] contributed to the proof of the validity of non-Euclidean geometry. In effect, Klein contributed to the establishment of non-Euclidean geometry as he showed that a geometry of positive curvature does satisfy the postulate of the straight line [31]. Yaglom connects the profound influence of Klein and his colleagues to Einstein’s special theory of relativity: “Thus, when we pass from the classical mechanics of Galileo and Newton to the relativity theory of Einstein and Poincaré, we are actually changing our view of the geometry of the surrounding world and this geometry, in full agreement with Klein’s point of view, is determined by prescribing the group of transformations which preserve the form of physical laws” [64, page 124]. Gross similarly notes that subsequent advances in quantum physics were made, in part, when “he [Einstein] put symmetry first . . . as the primary feature of nature that constrains the allowable dynamical laws” [29]. Einstein’s work was influenced by Noether’s theorem, which connected the invariance of symmetry under conditions of transformations (rotations, translations, and reflections) to the laws of conservation, connecting time, space, and movement with symmetry.

### *1.2. Biological basis of symmetry*

Symmetry runs deeper than the embodiments of bilateral symmetry found in humans and many other organisms. Biological and brain research provide evidence that visual symmetry detection is an evolutionarily old capacity, hardwired both in humans and other species [20]. Giurfa, Eichmann, and Menzel [26, page 458] assert that “even organisms with comparatively small nervous systems can generalize about symmetry, and favour symmetrical over asymmetrical patterns.” The perception of symmetry also appears central

to the operation of the human brain. It seems that the human brain is able to encode information efficiently, in part, because of “Information processing and symmetry; symmetry essentially allows us to encode only half of the information in a visual space, and automatically know the other half” [6]. The human brain has modular receptors to encode information onto orthogonal axes, an inherently symmetric system [25, 12]. Jayakrishnan, reporting on the work of O’Keefe, Brit-Moser, and Moser (winners of a Nobel Prize in Physiology), states that geometrical positioning or wayfinding is controlled by a positioning system, “an inner GPS” (Global Positioning System) in the brain, that makes it possible to orient ourselves in space, thus demonstrating a “cellular basis for higher cognitive function” [32, page 58]. According to O’Keefe [43] the hippocampus in humans and other species processes environmental and geometric information aided by place and grid cells. These grid cells “and other spatially periodic cells of the medial entorhinal cortex which fire in multiple locations across an environment in a symmetrical hexagonal pattern (grids)” [43, page 285]. Intriguingly, O’Keefe describes animal wayfinding such that “the constellation of cells appears to form a compass-like polar coordinate system upon which the rest of the spatial mapping system is built” [43, page 294].

### 1.3. Underrepresentation of symmetry in school mathematics

The robust uses of symmetry across cultures and domains reflect ways in which humans perceive, process, and record information. Yet, Tsang, Blair, Bofferding, and Schwartz [55] conclude, despite the human capacity to detect, perceive, create (via geometrical shapes), navigate, locate, and encode symmetry, that the potential that symmetry may provide in the teaching of school mathematics remains largely untapped.

A few important exceptions include the work of Saxe and his associates [49] and Tsang and her colleagues [55], who used the symmetric structure of integers to effectively teach positive and negative integers, origin on a number line, equal intervals, and simple and multi-units. Case *et al.* [11] use the notion of an orthogonal center (two lines perpendicular to each other) as a generalized schema for developing students’ competence in numbers and spatial location. Davydov and Tsvetkovich’s work [15] on comparison-of-quantities approach emphasizes measuring as a ratio relationship connecting algebraic thinking and a geometric number line. Bass [7] stresses the importance of the



geometric number line as an approach that presents aspects of real numbers in a developmentally appropriate way from students non-numeric comparison-of-quantities. Lockhart embraces the comparison-of-quantities approach because it is “scale independent” [41, page 34], accordingly he states that we are measuring a ratio relationship, an approach which generalizes. He connects the ideas and beauty of relative comparisons to geometry, size, shapes, and area. He further connects the concept of a geometric number line to ideas of motion, time, space, and location, fundamentally connecting geometry and arithmetic “in a very pleasing and beautiful way” (page 205). Sophian’s research in developmental psychology [51] provides evidence on the propensity of very young children to perceive early forms of proportions and comparison-of-quantities. She notes that numbers are abstract symbols while quantities are “properties of things that exist in the physical world” [51, page 3].

Dreyfus and Eisenberg note the importance of symmetry for students in understanding group theory, algebra, trigonometry, and calculus and go on to state, “The notion of symmetry is itself a mathematician’s dream . . . [it has been] generalized and applied to almost every area of mathematics” [19, page 189]. They conclude that “symmetry must be taught as it is too useful and important a topic to let it develop casually” (page 196). We agree with Tsang, Blair, Bofferding, and Schwartz (2015) and Dreyfus and Eisenberg (1998) that symmetry connects to many areas of mathematics and that the teaching of school mathematics through symmetry remains woefully underrepresented, despite increasing evidence for its biological and cognitive basis, and its practical utility. This article explores one way in which the dynamic and flexible use of symmetry and measuring has the potential to unify and generalize the teaching of school mathematics.

#### *1.4. Yupiaq activity as a basis for symmetry explorations*

We have long been interested in understanding the ways in which Yupiaq elders performed everyday tasks and solved problems in a context in which numbers were not typically relied upon and without the use of Western instrumentation [36, 39]. They created their tools and ways of thinking that allowed them to measure and locate in one, two, and three dimensions as they compared lengths, constructed geometrical shapes, made clothing and patterns, and star navigated. They performed these constructions by thinking in linear, coordinate, polar coordinate, and spherical coordinate space.

We knew that symmetry and measuring were key concepts for the Yupiaq [36]. However, in 2014 the group was intensely discussing how they conceived of spatial orientation while traveling and how they used that same frame of reference inside of a house. Notions of center, upriver/downriver, and sidedness were discussed and modeled and diagrams drawn on butcher block paper lined the walls of the room. At a quiet moment, Raphael Jimmy, a ninety-two-year-old elder and member of our research group raised two-crossed fingers (+) and said, “This is the center [*qukaq*] and beginning [*ayagneq*] of everything” (see Figure 1).

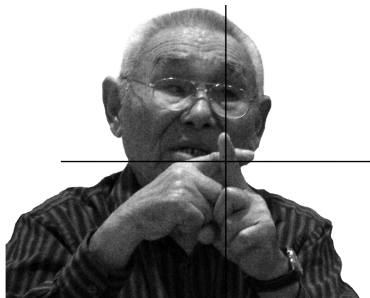

Figure 1: Raphael Jimmy, a ninety-two-year-old elder from Mountain Village, Alaska, identifies and symbolizes the center of everything. Mr. Jimmy is a key member in and contributor to our National Science Foundation-sponsored research project.

Quite simply, this was a defining moment for our research group, as we began to understand the centrality of this frame of reference. Subsequently, we investigated everyday tasks of the Yupiaq group members, and in every activity that we explored, from making snowshoes to mending nets to making ceremonial headdresses, the orthogonal center, symmetry, and measuring was central to the task. Through our collaborative work we determined that between these everyday constructions and tasks were a set of interrelated mathematical principles. They are symmetry, measuring-as-comparison, repeated halving including an elegant folding algorithm, and verification in a mostly non-numeric context. Similarly, we observed that knowledge holders from the Caroline Islands in Micronesia, a vastly different cultural, geographic, and linguistic environment, also use symmetry, center, halving, and measuring across a range of activities, from boat and canoe building to weaving and navigating [1, 27, 53]. We believe that what we have learned from Yupiaq and Carolinian elders, that is their elegant, systematic, and generalized way of using measuring and symmetry, provides a pathway to extend

previous work done in school mathematics.<sup>3</sup> The rest of this paper explores our generalized approach.

### 1.5. *Our approach*

We weave mathematical connections across different mathematical concepts of symmetry, measuring, center, halving, and embodiment (for example, counting on the body). The recurring processes, structures, and representations associated with symmetry and measuring are both generative and integrative while “naturally” connecting quantities, units, and numbers. Through distance, number, quantity, location, and measuring, we will show how the mathematical strands of number (algebraic and arithmetic thinking including ratios, exponentiation, primes, composites, and factors) and geometry (shape, properties, congruence, and similarity) connect, and how these connections develop into the understanding of linear and trigonometric functions.<sup>4</sup>

Using symmetry, center, measuring, halving, and verifying, we begin with simple comparison-of-quantities, quantity  $a$  compared to quantity  $b$  ( $\frac{a}{b}$ ), then we map the comparison onto an orthogonal grid which connects measurement, location, and number. This approach leads to a panoply of geometric constructions and relationships by applying symmetry and measuring to irregular and uneven material to create a host of planar shapes. The construction and exploration of accessible shapes, such as the right isosceles triangle and the  $30^\circ$ - $60^\circ$ - $90^\circ$  triangle, highlights their importance in the unit circle and trigonometry. To develop these concepts, we briefly explore irrational numbers through measuring-as-comparison, then connect measuring-as-comparison (ratios), center, and symmetry to linear functions. Connecting measurement, location, number, and symmetry through the orthogonal grid and the unit circle culminates in a method to access and understand concepts

---

<sup>3</sup> Although elders do not use written symbols and typically do not engage in formal Western school mathematics, they encouraged our long-term group to adapt their knowledge to school mathematics.

<sup>4</sup> Clearly the exploration of symmetry and measuring does not end with trigonometry, as they can be connected to calculus, imaginary numbers, and other mathematical concepts. Given the space limitations, we choose to end our discussion at trigonometric functions.

of trigonometry. This pathway highlights the generative and cohesive nature of symmetry and measuring.

## 2. Spatial Orientation System: Connecting Symmetry, Measuring, and Halving in One Dimension

We begin with one pair, two points, which define a line, illustrated in Figure 2(a). Through folding along the line segment AB placing point A on top of point B, we identify a center. We can verify that the distance from A to the center is the same as the distance from the center to B under conditions of rigid transformations. The act of folding also invokes a line of symmetry. This establishes a fundamental symmetric structure that can be generalized from one dimension to two dimensions through rotation, as shown in Figure 2(b). Symmetry and measuring-as-comparison are fundamentally connected to the “center of everything” (+). The orthogonal center is composed of binary pairs of opposites: above/below and right/left (sidedness). These foundational structures will be used throughout this discussion.

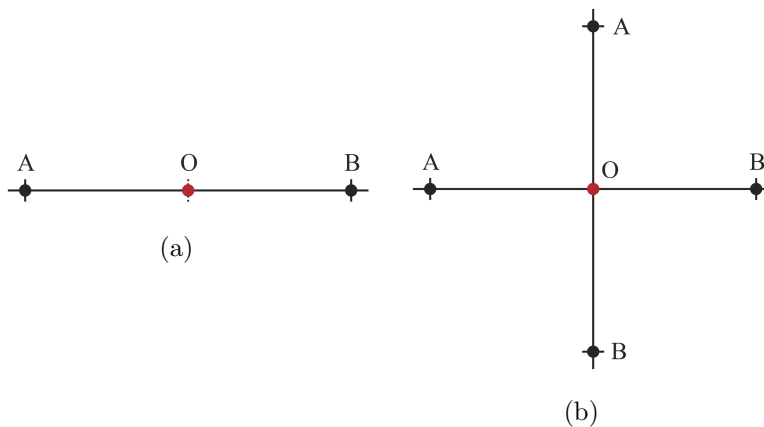

Figure 2: a: Symmetric structure in one dimension. b: Symmetric structure in two dimensions.

These symmetric/structures are also embodied in the Yupiaq counting and spatial orientation system (Figure 3). The four sets of digits are counted and spatially organized by the body’s vertical line of symmetry (left/right) and above and below the center. This schema connects number, position

(above, below, left and right), movement, and geometry. This representation is useful in Yupiaq practical activities as well as in school mathematics. For example, the Yupiaq oral counting system has been represented on an embodied abacus, thus connecting through bilateral symmetry and an implied up/down line of symmetry a way of counting, grouping, and organizing numbers spatially while laying the foundation for a place value system.

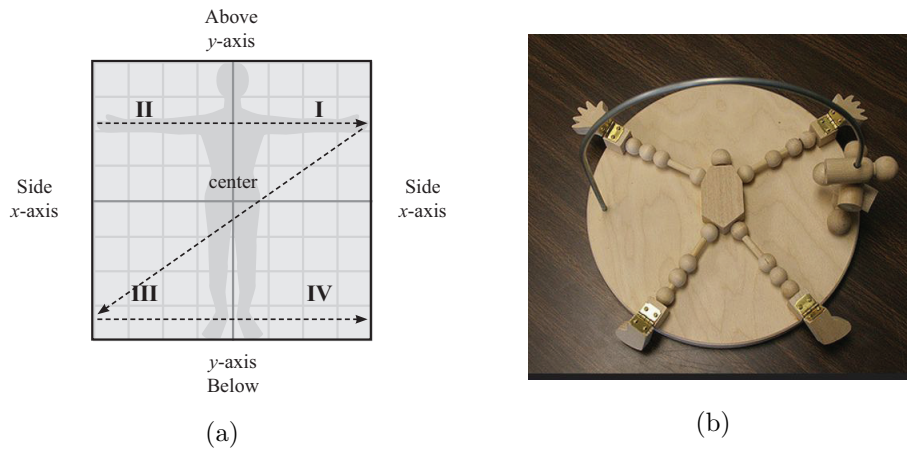

Figure 3: Symmetric structure in two dimensions imposed on the Yupiaq embodied counting system and Yupiaq abacus include origin, orientation, and unit.

Burch defines symmetry as, “*Two points on different sides of a line are symmetric about the line if the distance between them is twice the distance of each of them on the line*” (italicized in the original) [10, page 16]. Under conditions of rigid transformation — translations, reflections, or rotations — the distances  $AO$  and  $BO$  are invariant, which is an isometry highlighting the Greek conceptions of symmetry and measuring. Students can verify that these distances remain the same. Symmetry connects measuring, distance, proportionality, halving, and relational thinking in an accessible way. Burch’s definition of symmetry includes a comparison-of-quantities by defining their relation to each other, that is, for this length  $AO$ , we can prove

$$2(AO) = AB$$

or conversely

$$\frac{AB}{AO} = 2 \quad \text{or} \quad \frac{AB}{BO} = 2.$$

Further, this structure provides a model for comparison including properties of equality, less than, greater than, and equal to, and arithmetic operations. For, example,  $AB = AO + BO$ ;  $AB - AO = BO$ . The structure also provides a concrete model both for showing that adding/subtracting and multiplying/dividing are inverse operations and for building abstractions.

Similarly, Lockhart [41] also connects measuring to ratios as he compares two sticks, one twice the length of the other. He states, “What exactly are we doing when we measure? I think it is: we are making a comparison. We are comparing the thing we are measuring to the thing we are measuring it with. In other words, measuring is relative . . . it’s the proportion (that 2:1 ratio) that’s the important thing” [41, page 32]. Measuring as a comparison-of-quantities is a fundamental and accessible structure that reveals the relationship between the quantity being measured and the unit of measure; the outcome of measuring quantities is numbers. Measuring, in effect, becomes a prototype for division and early forms of multiplication, such as repeated addition or iterating a unit. Similarly, measuring as a comparison-of-quantities approach uses children’s pre-numerical experiences exploring quantitative relationships as a means of developing algebraic thinking [14, 56, 18, 50].

### *2.1. Comparing quantities in one dimension as a way to explore real numbers with repeated halving*

Cross-cultural, child development, and brain research all support the idea that halving, the practice of dividing a whole into two parts made precisely equal through comparison, is a widely known and pedagogically accessible mathematical practice [5, 42, 51]. Yupiaq and Carolinian knowledge holders use repeated halving of pieces of string, strips of paper, or coconut fronds, etc. to create measuring tools. Carefully produced halves of halves of halves create precisely equal units and the resulting tool can be used to measure lengths and distances [38, 1, 2]. Mathematically, the act of folding a whole in half and half again (repeated halving or recursive folding) provides a way to model exponential numbers, powers of 2, and positive and negative integers in relation to the origin.

In Figure 4, a length is recursively folded in half to form eight parts. In actual practice, when folding paper or other materials, accuracy in repeated halving is achieved non-recursively. The whole is folded in half, and each section is then individually folded in half and made precise by comparing and aligning



Figure 4: Symmetric structure and exponentiation.

the two halves. Each fold establishes a line of symmetry, while physical verification establishes the distance from the center (the new line of symmetry on one side is equal to the distance on the other side). Symmetry, measuring, halving, and verifying are used to ensure that the intervals are equal. The original length is now divided into a series of units and related subunits Tsang *et al.* [55] and Saxe and Shaughnessy [48] use this symmetric structure, a number line representation, to teach positive and negative integers. Any point on one side of the line of symmetry formed by a center point of a number line or origin has a corresponding point on the opposite side. Movement, magnitude (amount of distance), and direction form a basis for understanding positive and negative numbers, addition/subtraction, location in space, and a building block for understanding vectors.

### 2.2. Exploring numbers: folding algorithm, even and odd, primes and composites

Binary folds create powers of two, resulting in four, eight, and so on parts for either whole or fractional numbers. Annie Andrews, Dora Andrew-Ihrke's<sup>5</sup> mother, recognized that powers of two were “easy folds”. “Difficult folds” comprise prime numbers (excluding 2) and composite numbers that include an odd factor. To create an odd number of parts, Dora follows her mother's instruction using an  $n - 1$  folding algorithm, where  $n$  is any odd number of parts. She incorporates the fundamental symmetric structure as she generates three, five, seven, or more odd number of equal parts.

Figure 5 is an example of how constructing five ( $n$  parts in general) equal parts beautifully demonstrates symmetry and measuring. This way of thinking, manifested through folding, illustrates the relationship between length and number of parts. Focusing on length, we subtract one estimated part

<sup>5</sup> Dora Andrew-Ihrke is a long-term Yupiaq colleague and major contributor to this work. She has advanced the practices and extended the traditional knowledge that her mother passed onto her.

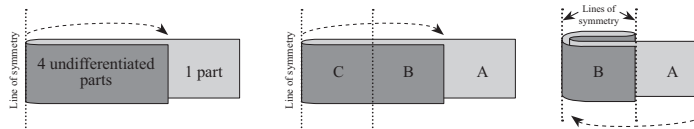
Figure 5:  $n - 1$  halving algorithm for constructing  $n = 5$  parts.

( $A$ ) that will need to be  $\frac{1}{n}$ th of the total number or total length. By folding the remaining part in half, we create a new line of symmetry, in which the  $\frac{n-1}{2}$  parts are equal; thus, parts  $B + C$  are also equal to  $D + E$ , the section hidden. We adjust our folds to ensure that the property is achieved. Halving again creates four ( $n - 1$ ) equal overlapping parts  $B = C = D = E$ , and each part also equals  $A$ ; hence, five ( $n$ ) equal parts form the total length where each part is of reciprocal length, in this case  $\frac{1}{5}$  of the original length ( $\frac{1}{n}$ th in length). Creating composite numbers from a prime, for example 10, can be accomplished by dividing the five overlapped parts in half, yielding ten equal parts. This powerful folding algorithm can model odd and even numbers, a limited set of prime numbers, composite numbers and their factors, and exponential numbers. Symmetry is used dynamically in this algorithm, shifting the axes of symmetry depending upon the number of parts required or based upon a particular task. This dynamic use of symmetry underscores the generative and cohesive nature of symmetry as a principle and a practice.

This comparison-of-quantities approach leads to explorations of operations with fractions, factors, and common denominators, for example. Although not addressed in this paper, our approach, in essence, starts with division of whole numbers and extends to division of a unit length to create fractions through the folding algorithm. Additionally, we can use the comparison-of-quantities approach to compare two lengths that may not immediately resolve into an integer. Briefly, by comparing the magnitude of the two lengths, fold back the difference between them, then use the difference as a divisor (the new unit of measure). Repeat this process until a common unit or the greatest common divisor is found [37]. This particular folding algorithm that Dora Andrew-Ihrke and some other elders use to find a common unit is the physical undertaking of Euclid's algorithm [22, 23], although the number of iterations is limited due to the material nature and physical procedure.



### 2.3. Pythagoras, symmetry, and numbers

In the work of Pythagoras (sixth to fifth century B.C.), symmetry was a central property when attributing value, worth, or meaning to numbers [60, page 5]. Numbers were represented by pebbles placed in sand, making specific configurations that represented geometric figures. Numbers were also “divided into classes: odd, even, even-times-even, odd-times-odd, prime and composite, perfect, friendly, triangular, square, pentagonal, etc.” [52, pages 41–42]. These configurations of numbers were called figurative numbers. According to principles of symmetry, Greek mathematicians labeled figures as even numbers if the geometric layout had two axes of symmetry. Those with two axes of symmetry were also considered female or undetermined. Figures were called odd numbers if their layout contained four axes of symmetry and were also called male or determined [4, page 1560]. Figures 6 and 7 illustrate the difference between these categories and their social valuation, reflecting the patriarchy of the time [24].

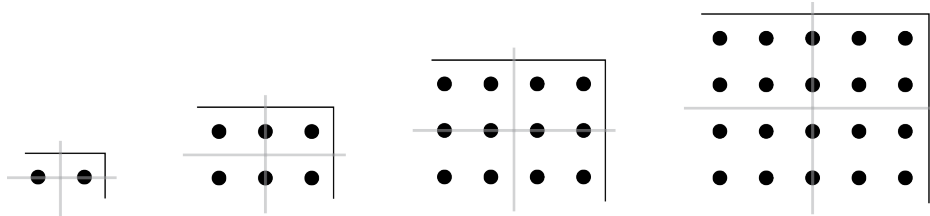

Figure 6: Even Greek figurative numbers called female or undetermined showing 2 symmetry axes.

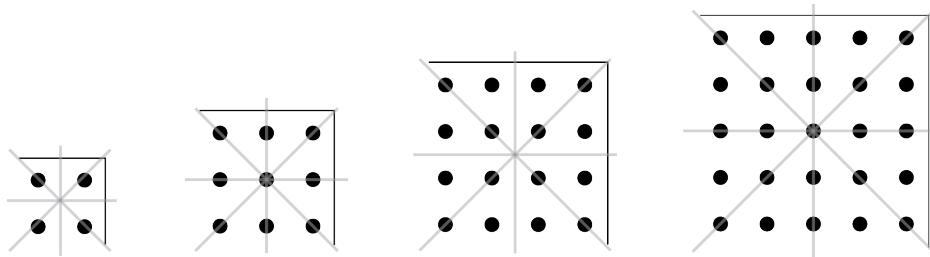

Figure 7: Odd Greek figurative numbers called male or determined showing 4 symmetry axes.

A rectangle (having two symmetry axes) was thought to be less perfect than a square (which has four symmetry axes) and thus was less valued because

of the lower amount of symmetry axes. Indeed, the most perfect geometrical figure is the circle. Plato [44] argued the perfection of the circle because of its infinite amount of symmetry axes. The same argument was used by Birkhoff [8] when he coined the formula of the beauty of (geometrical/mathematical) objects:

$$M = \frac{O}{C},$$

where  $M$  stands for “esthetic measure”;  $O$  stands for “order” (or the number of symmetry axes), and  $C$  stands for “complexity” (or the number of corners).

Although different from the Greek figurative numbers, our work also encourages students to use geometric layouts, in addition to the folding algorithm to investigate numbers. The examples shown in Figure 8 demonstrate how physical orientation and manipulation can be used practically by students to derive properties and rules of numbers through symmetry, which supports algebraic thinking. The exploration in this example from our developing school mathematics curriculum aligns with the understanding of numbers developed through the folding algorithms demonstrated above to construct even and odd, prime and composite, and exponential numbers. Similar to the  $n - 1$  folding algorithm, this approach uses the ideas of one left over, or one more than a pair, and the unpaired one, to allow even young children to derive rules and patterns associated with odd and even numbers through symmetry.<sup>6</sup>

#### 2.4. Place value example

The concept of place value is a direct extension of the comparison-of-quantities, symmetry, and measuring approach. We continue to follow Lockhart’s [41] formulation of

$$\frac{\text{quantity}}{\text{unit of measure}}$$

In our developed curricula, we establish a measuring context in which students develop a set of measurement tools in correspondence to a particular base that is being taught. This method develops directly from the easy folds (powers of 2) and the  $n - 1$  folding algorithms shown above.

---

<sup>6</sup> See Strogatz, Feb. 7, 2007, *New York Times*, [http://opinionator.blogs.nytimes.com/2010/02/07/rock-groups/?\\_r=0](http://opinionator.blogs.nytimes.com/2010/02/07/rock-groups/?_r=0), last accessed on January 29, 2019.

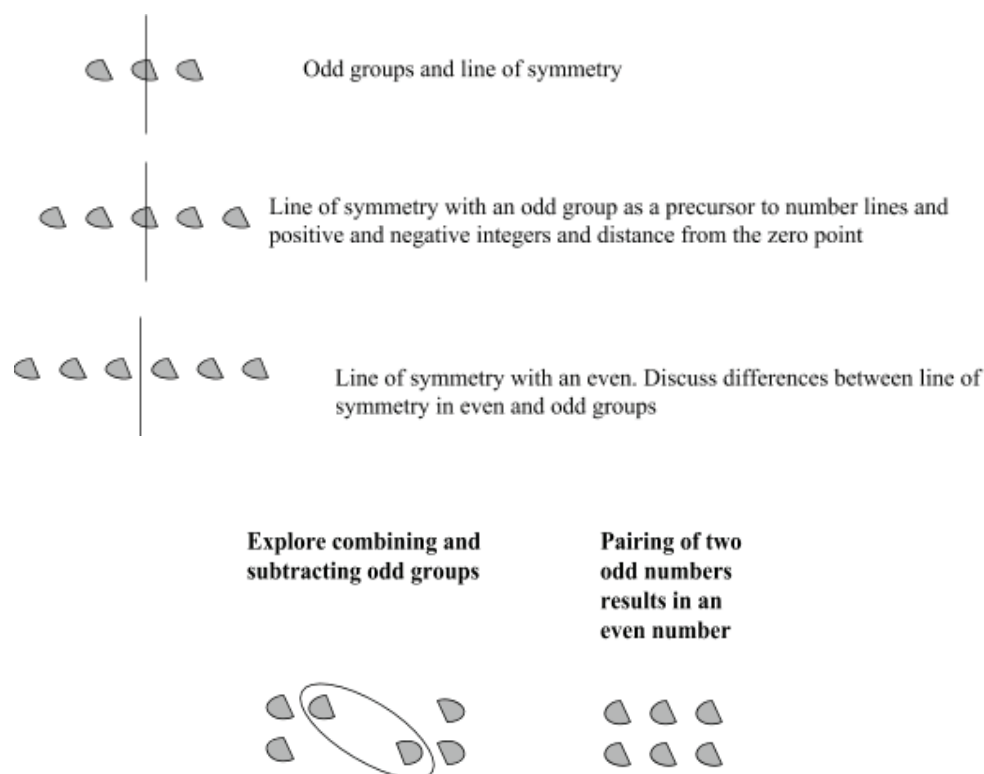

Figure 8: Using geometric layouts to explore rules and patterns with numbers (extracts from teaching materials).

Similarly, Venenciano, Slovin, Zenigami, and Yagi [57], among others have adapted and implemented Davydov's measuring-as-comparing approach to a U.S. context through a program called *Measure Up* at the University of Hawai'i at Mānoa. We begin with base 2 because of its accessibility through recursively folding paper in half and its practicality as evidenced by the many Indigenous and non-Indigenous groups that use halving and doubling. Parenthetically, this relates to the use of binary numbers (0/off state and 1/on state) and base 2 in computer systems.

To operationalize base 2 place value, we provide a set of examples showing how students would produce their tools, measure, and encode in base 2. Using recursive folding as shown in Figure 9, students create the elements

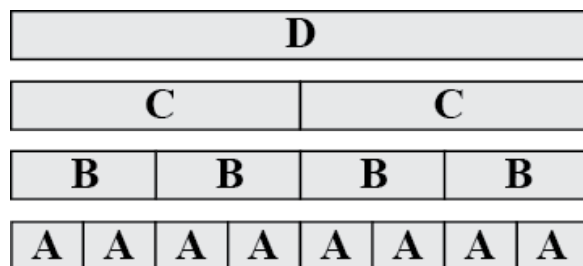

Figure 9: Measurement units created through recursive folding.

for their measuring kit, shown in Figure 10, that initially has four lengths and only one unit of each paper strip measure, where Length  $D$  is twice as long as Length  $C$ ; Length  $C$  is twice as long as Length  $B$ ; and Length  $B$  is twice as long as Length  $A$ .

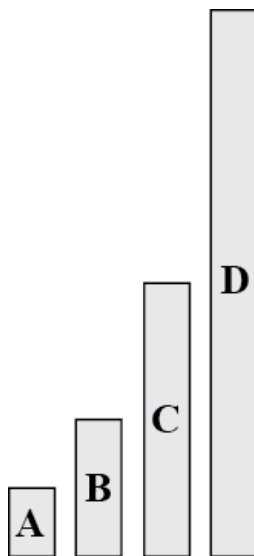

Figure 10: Initial base 2 measuring kit.

The resulting length ratios form the place value understanding:

$$\frac{A}{A} = 1 = 2^0; \quad \frac{B}{A} = 2 = 2^1; \quad \frac{C}{A} = 4 = 2^2; \quad \frac{D}{A} = 8 = 2^3,$$

where  $2^0$  represents the units (or ones) column,  $2^1$  the twos column,  $2^2$  the fours column, and  $2^3$  the eights column. This parallels base 10 with the ones, tens, hundreds, and thousands columns.

Students explore the relationships of these different measuring units  $A$ ,  $B$ ,  $C$ ,  $D$  through comparison, while the quantities to be measured are noted as Greek letters. The measuring units are compared with the quantities to be measured, which establishes numeric patterns represented in the recording table. This process assists students in understanding the positional base notational system. They record in binary code, meaning if they use the length, they record 1, and if not, they record 0 in the appropriate column.

Measuring unit  $A$  equals the length of Object  $\Delta$ , as visually represented as a comparison-of-quantities in Figure 11 (and subsequent figures). Students record 1 in the  $A$  column to show that one Length  $A$  was used and a zero in all other columns to indicate that no other measuring unit was used.

$\Delta$		<b>E</b>	<b>D</b>	<b>C</b>	<b>B</b>	<b>A</b>
$\Delta$	$\Delta$	<b>0</b>	<b>0</b>	<b>0</b>	<b>0</b>	<b>1</b>

Figure 11: Measuring length of Object  $\Delta$  using measuring unit  $A$ .

However, Length  $A$  is too small to measure Object  $\Omega$ . Two Length  $A$ s would be needed to measure it. When students realize there is only one Length  $A$  in the kit, they simply cannot measure it with 2 unit  $A$ s. This challenge ushers in the need for substitution through equivalency (Figure 12(a)). They can immediately observe that if they had two Length  $A$ s, they would measure the second object, but they have to use Length  $B$ , as it is equivalent to two Length  $A$ s. Thus they substitute Length  $B$ , as shown in Figure 12(b), and follow the same steps to record it in the place value table.

$\Omega$	$\Omega$	$\Omega$		<b>E</b>	<b>D</b>	<b>C</b>	<b>B</b>	<b>A</b>	
<b>A</b>	<b>A</b>	<b>B</b>	<b>B</b>	$\Omega$	<b>0</b>	<b>0</b>	<b>0</b>	<b>1</b>	<b>0</b>

(a) (b)

Figure 12: (a) Substituting. (b) Recording.

The substitution allows students to move to the next column to the left in the place value table. Students record that they used 1 Length  $B$  and 0 Length  $A$ . The specific measuring code for the second object is  $10_2$

(read as “one zero”) in base 2. The process continues as they measure Object  $\Sigma$ , which requires them to use both measuring units  $A$  and  $B$  (see Figure 13).

$\Sigma$			$E$	$D$	$C$	$B$	$A$
$B$	$A$	$\Sigma$	0	0	0	1	1

Figure 13: Recording table representation for Object  $\Sigma$  using measuring units  $A$  and  $B$ .

Similarly, Object  $\Lambda$  requires both measuring units  $C$  and  $B$  in Figure 14.

$\Lambda$			$E$	$D$	$C$	$B$	$A$
$C$	$B$	$\Lambda$	0	0	1	1	0

Figure 14: Recording table representation for Object  $\Lambda$  using measuring units  $B$  and  $C$ .

Object  $\Phi$  requires the students to use the complete set of units, resulting in the recording of  $1111_2$  indicating that all units were used (Figure 15).

$\Phi$						$E$	$D$	$C$	$B$	$A$
$D$	$C$	$B$	$A$		$\Phi$	0	1	1	1	1

Figure 15: Recording table representation for Object  $\Phi$  using all of the existing measuring units.

However, when they attempt to measure Object  $\Theta$ , they realize that their measuring kit has run out of measuring units (Figure 16).

$\Theta$			
$D$	$C$	$B$	$A$

Figure 16: Problem solving how to measure an object longer than the existing measuring units.

This dilemma promotes further exploration of the place value system, as the students need to develop a new measuring unit.

Measuring unit  $E$  follows the established pattern and is twice the length of measuring unit  $D$ . Measuring unit  $E$  measures Object  $\Theta$  and is recorded as  $10000_2$  in base 2 notation.

Students are challenged to create the next length in the sequence once they have used lengths  $A$  through  $D$  to measure Object  $\Theta$ , which is longer than the existing set of measuring units. Students intuit that the next length in the system would be called measuring unit  $E$ , which is twice the length of measuring unit  $D$ .

$\Theta$		<b>E</b>	<b>D</b>	<b>C</b>	<b>B</b>	<b>A</b>
<b>E</b>	$\Theta$	1	0	0	0	0

Figure 17: Creating a new measuring unit for Object  $\Theta$ .

Through practice and measuring selected objects, students explore equivalence relations through exchanging units. In a school context, we would have a recording table that reflects the proportional relationship between each measuring unit, bridging the abstract concept of place value with the physical materials and representations. The next step is to move to the notational representation independent of the physical tools; this builds on our earlier work in understanding place value in multiple bases [33].

The process continues as described above. Students measure multiple objects designed so that they continually experience the process of adding a unit, substituting the next unit from the tool kit, and moving from one place value column in a right-to-left direction. In fact, this example models any positional number place value system, and may enhance understanding of base 10. The outlined approach provides a template for students to explore any base limited by the practicality of the physical tools. (See [37] for a description of how this approach connects recursive binary folding to place value in base 2.) Much as the students are learning through measuring, Yupiaq craftsmen, seamstresses, and others engaged in traditional activities use the tools of symmetry, measuring, and halving as they solve practical problems and develop a deep, practical understanding of the underlying principles. It is the depth of this understanding that makes it useful as a basis for teaching mathematics.

### 3. Symmetry, Measuring, and Halving in Two Dimensions: Connecting Numbers and Geometry

Raphael Jimmy's center of everything is the intersection of two line segments forming an orthogonal center. This fundamental symmetric structure is now applied in two-dimensional space.

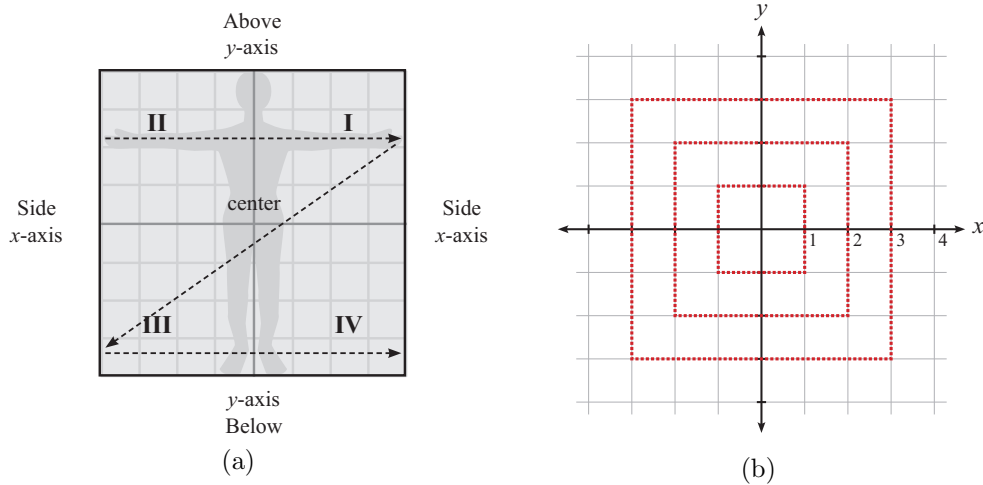

Figure 18: (a) Extended grid system. (b) Embodied orthogonal grid and symmetric structure.

Figures 18(a) and 18(b) illustrate the two-dimensional symmetric structure mapped on the body as a way to measure distance, movement, and number in space. The Yupiaq embodied counting system, base 20 sub base 5, combines aspects of an orthogonal grid system, symmetric structure, numbers, location, and orientation. The body's vertical line of symmetry establishes the right/left axis (y-axis), while the horizontal axis (x-axis) divides above and below. The above/below and right/left axes are common referents for many cultural groups [62], and this structure is potentially genetically encoded [32]. This orthogonal structure appears to frame the embodied Yupiaq vigesimal counting system. The first set of five digits moves from the left pinky finger toward the center and is reflected across the "upper" part of the body, crossing the body's vertical axis of symmetry. After the above ten digits are counted, the count moves diagonally and downward through the orthogonal center to the set of digits located below.



Again, counting on the bottom moves toward the center, crosses the center to the other side, and the other five digits are reflected on the other side. The count is completed when all twenty digits have been counted. This system partially resembles Descartes' coordinate plane.

The orthogonal coordinate system is named after Descartes, who introduced the method of rectilinear coordinates, providing a link between geometry and algebra. As these coordinates are the foundation of analytic geometry, Descartes can be considered the founding father of analytic geometry, combining geometry and algebra [34]. Another definition of symmetry can be obtained by using the Cartesian coordinate system. Symmetry is prevailing if we have “invariance with respect to transition from one Cartesian coordinate system to another; this symmetry comes from the rotational symmetry of space and is expressed by the group of geometric rotations about 0” [60, page 134]. In fact, mathematical examples from Yupiaq material practices are presented in Figures 19 and 20. In each example, imposing the constructed objects on the coordinate system to show the symmetries creates the link between algebra and geometry.

Translation symmetry is associated with counting and movement toward and away from the center. In addition, this fundamental schema of the Yupiaq spatial orientation system embeds angular motion, positional movement, space, time, distance, and orientation. Some Yupiaq elders use this two-dimensional symmetric structure by applying halving, symmetry, measurements from the center on the  $y$ - (above/below) and  $x$ - (sides) axes, and congruence to construct planar shapes around the orthogonal axis. We pay particular attention to constructing squares, circles, hexagons and their interrelationship with right isosceles and the equilateral triangle within the unit circle and its connection with trigonometric functions as a way to highlight how measuring and symmetry are accessible, generative concepts and processes for teaching and learning mathematics.

#### **4. Geometry, Number, and Location: Comparing, Measuring, Symmetry, and Halving**

We shift our attention from numbers to geometry by employing symmetry, measuring, center, and the same halving folding algorithm in two-dimensional space. Instead of dividing a line or a length into equal parts of a whole,

we use the orthogonal center to partition  $360^\circ$  into equal parts. These everyday Yupiaq constructions of geometrical shapes can easily be applied to school mathematics. These constructions rely on the concepts of origin, orientation, unit, and number. We apply the concepts of comparison as measuring, symmetry, and halving to locate two-dimensional shapes on the orthogonal grid system. Along the way, we show how the comparison-of-quantities approach applied to geometry is one way of introducing irrational numbers.

We begin the section with a brief description of how Yupiaq elders construct squares and circles. We connect the comparison-of-quantities approach with Pythagoras' theorem to derive the square root of 2; similarly, geometrical constructions of hexagons and equilateral triangles connect to the square root 3, hence deriving exact trigonometric values. Lastly, we approximate  $\pi$  by comparing the the length of the circumference to the diameter of a circle.

#### 4.1. Constructing squares and circles: measuring, symmetry, halving, scaling

The spatial orthogonal orientation system guides the construction of everyday artifacts as well as geometrical constructions. Elders envision an orthogonal grid system as they use symmetry, proportionality, and geometric similarity to construct geometric shapes. When using this approach to teach, all constructions can begin with irregular material (Figure 19(a)) to emphasize the connections to everyday activity as well as to focus on the envisioned symmetric structure (+) and its orthogonal center.

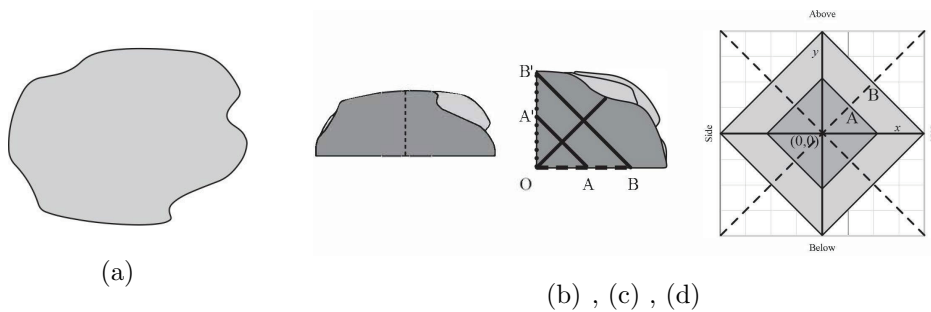

Figure 19: (a) Irregularly shaped material. (b), (c), (d) Constructing scaled squares from the irregularly shaped material through halving, center and symmetry.

In the circle and square constructions, the first steps are simply to fold the irregularly shaped material in approximately half in one direction (Figure 19(b)) and in half in the other direction along the axis created by the first fold (Figure 19(c)), thus establishing the orthogonal center of the soon to be circle and/or square. In Figure 19(c), there is an additional fold bisecting the center, and the line drawn on the fold line is used as a guide to scale the square by a particular scale unit,  $A$  or  $B$  in this case. The scaling of the square, circle, or other regular polygons demonstrates the concept of area as squared space and models geometrical similarity. The scaled square (Figure 19(d)) is determined by an equal distance measured from the origin along the  $x$ - and  $y$ -axes. In this diagram  $AO = OA'$ , which is half the length of the diagonal of the smaller square. Raphael Jimmy conceptualizes the square using the attribute that the diagonals of a square bisect at right angles. Hence, the line drawn from  $A$  to  $A'$  on Figure 19(c) forms the sides of the square, and its length can be determined by the application of Pythagoras' theorem. His folding ensures that each right isosceles triangle is congruent. The same process is used to create the circle and sets of scaled circles as shown in Figure 20, by cutting in an arc rather than a straight line. The same processes can be used to construct other geometric shapes (for example other  $n$ -gons, triangles, rhombus, and an ellipse), providing opportunities to compare properties of different geometrical shapes in a learning environment.

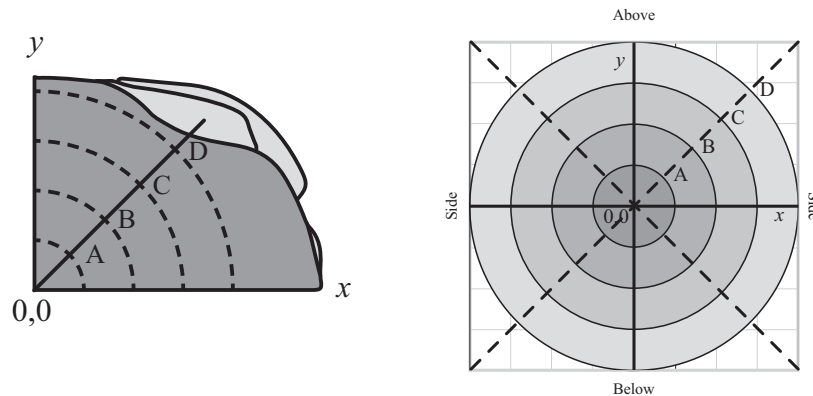

Figure 20: The circle construction, center, symmetry, and scaling.

4.2. *Constructing hexagons and equilateral triangles using the same approach*

Now, we use the same processes of symmetry, measuring, and halving to first find the center in order to construct a hexagon,<sup>7</sup> shown in Figure 21, as well as an equilateral triangle. The  $n - 1$  folding algorithm used to create three equal parts in one dimension is now used in an orthogonal axis to create three equal angles or sectors, shown in steps (a) and (b). Three additional congruent sectors are folded behind; this occurs on the  $y$ -axis as shown in steps (c) and (d). To complete the task, measure the length of the hexagons diagonals from the center and cut out the planar shape, ensuring that the distance from the center to  $p$  is equal to the distance from the center to  $q$  (step (e)) and the distance  $pq$  is equal to the distance from the center to  $p$ . Unfold the resulting equilateral triangle (step (f)) to create the hexagon (step (g)).

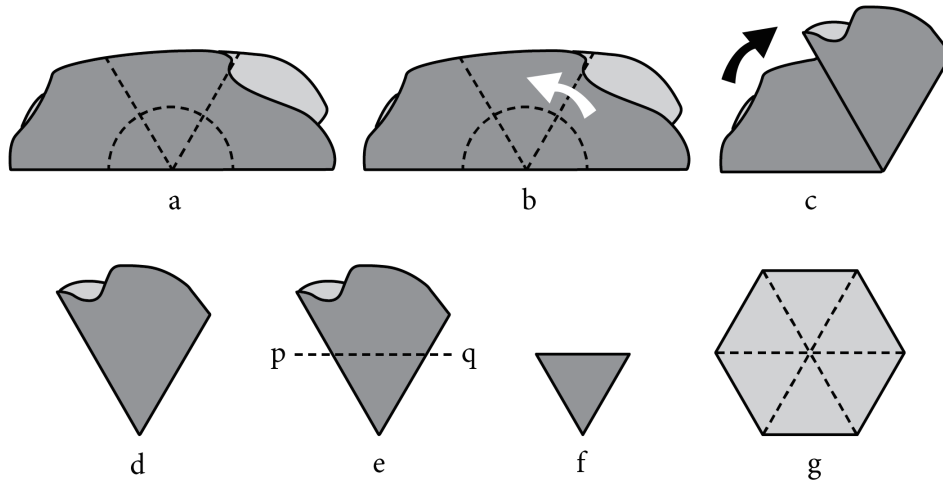

Figure 21: Hexagon construction.

For the equilateral triangle, instead of cutting straight across as in Figure 21(e), draw a perpendicular line from  $A$  to  $O$ , forming six copies of a  $30^\circ$ - $60^\circ$ - $90^\circ$  triangle (Figure 22). The same  $60^\circ$  angle is at the center of both

<sup>7</sup> The hexagon construction also includes the construction of a trapezoid and rhombus and, as mentioned, an equilateral triangle. Through symmetrical halving we can create the  $30^\circ$ - $60^\circ$ - $90^\circ$  right triangle.

folded objects for the hexagon and equilateral triangle. Unfold triangle  $AOB$ , paying attention to the symmetry of the construction. The large equilateral triangle contains six smaller  $30^\circ$ - $60^\circ$ - $90^\circ$  triangles.

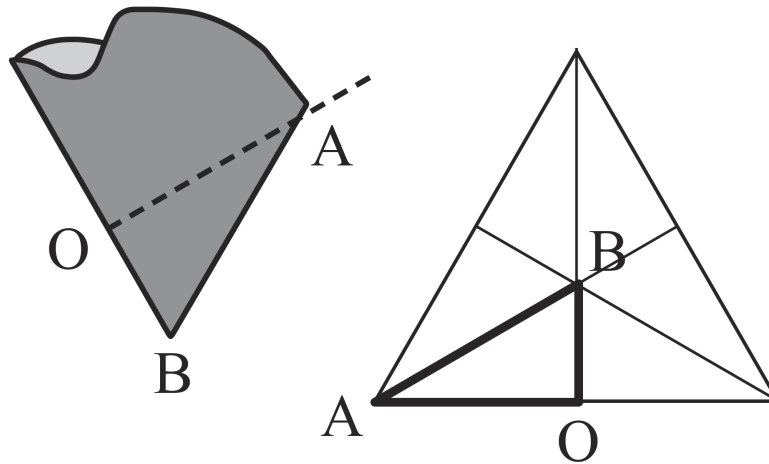

Figure 22: Constructing an equilateral triangle using the same folds as the hexagon construction.

Composing and decomposing shapes provides an enjoyable, self-reliant way for students to learn about geometric properties, definitions, area, perimeter, geometrical similarity, congruence, and measuring shapes (comparison-of-quantities). This approach emphasizes some of the fundamental ways in which these diverse geometrical shapes are related to each other and provides a dynamic perspective, starting from the center with movements around the center. These shapes can also be placed on an orthogonal grid as a way to further formalize students' understanding. For example, once on an orthogonal grid, number can be applied, location can be measured, distances can be calculated, and area and perimeter can be investigated.

#### 4.3. Pythagoras and Raphael Jimmy

Mr. Jimmy's construction of the square from a right isosceles triangle provides students with a physical and visual example of Pythagoras' theorem,  $a^2 + b^2 = c^2$ . The physical proof of Pythagoras' theorem is a physical comparison-of-quantities, as illustrated in Figure 23.

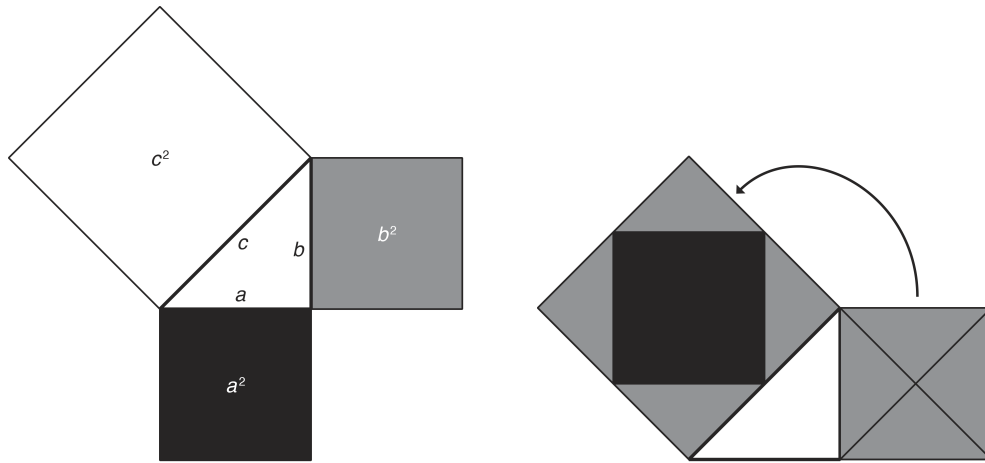

Figure 23: Using Raphael Jimmy’s square construction to visually demonstrate a physical comparison of areas introduces squaring and square roots and a physical proof of Pythagoras’ theorem.

Instead of comparing lengths as we did in one dimension, we compare area, or lengths squared, in two-dimensions. Parenthetically, during professional development workshops conducted by some of the authors, teachers have found this demonstration an epiphany, as it literally clarifies what “squaring” a length means. Symmetry, measuring, and verification through congruence makes the theorem accessible. Comparing the area  $a^2$  to the area  $c^2$ , we see some space is still left over. The leftover space can be fit into the area  $b^2$  perfectly, physically proving that the theorem holds true.

#### 4.4. Squaring to Square Root

We continue the physical comparison-of-quantities by measuring the  $\frac{\text{hypotenuse}}{\text{side length}}$  of an isosceles right triangle. Using the elders’ folding algorithm to compare differences, we fold back the difference between the length of the hypotenuse and the side length. The difference is the new divisor. We continue this process as we find a new difference and begin to realize that we cannot resolve these “incommensurable” differences. Folding back the difference between the length of the hypotenuse compared to the side length of the isosceles right triangle results in an approximate value, as this comparison produces an irrational number (Figure 24). A similar triangle, scaled to the hypotenuse of length 1, shown in Figure 25, is used later in this paper.

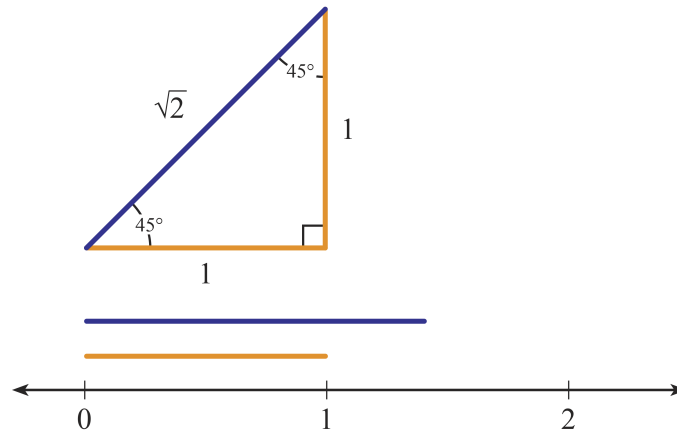

Figure 24: Comparing the side length 1 to the hypotenuse length  $\sqrt{2}$  on a number line.

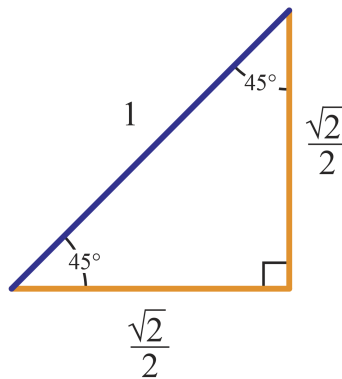

Figure 25: Geometrical similarity demonstrated by scaling the triangle in Figure 24 so that the hypotenuse has a length of 1.

The fact that folding does not quite resolve is an indication that we are “approaching” a different kind of number. Just as our work with length  $a$  times length  $a$  led us to  $a^2$ , a square, now we use our approach to begin to establish the concept that a square root of a number is the value of the length of the hypotenuse in a right isosceles triangle and that some square roots cannot be reduced to a whole number. Similarly, we compare the quantities  $\frac{\text{hypotenuse}}{\text{side length}}$  and the quantities  $\frac{\text{hypotenuse}}{\text{height}}$  of the  $30^\circ$ - $60^\circ$ - $90^\circ$  right triangle, resulting in side lengths 1 and  $\sqrt{3}$  and a hypotenuse of 2, shown in Figure 26 and scaled to a hypotenuse of length 1 shown in Figure 27.

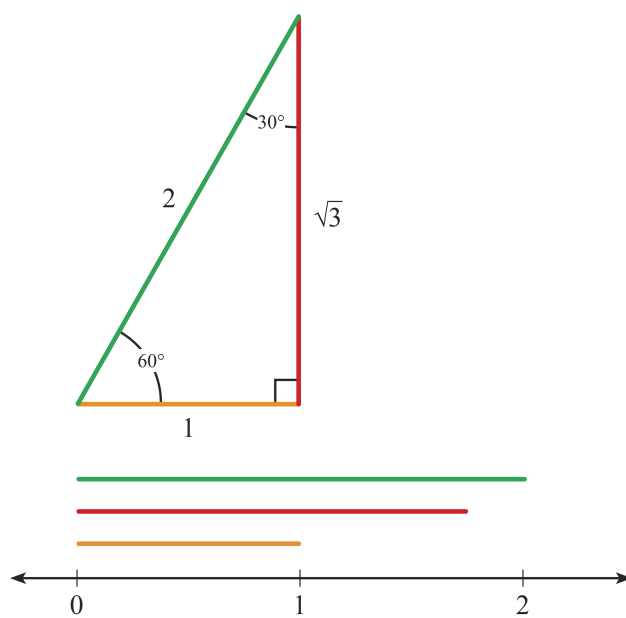

Figure 26: Square root of 3 compared to hypotenuse and side length.

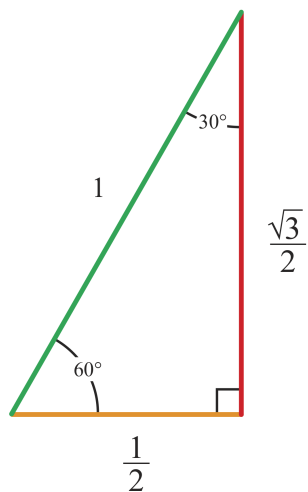

Figure 27: Geometrical similarity demonstrated by scaling the triangle in Figure 26 to have hypotenuse of length 1.



These are some of the mathematical ingredients we will need as we continue developing the symmetry and measuring-as-comparison approach applied towards trigonometry — ratios, squaring, square roots, and special right triangles.

## 5. Linear Functions: Space, Location, Algebra, and Geometry

Before we move to trigonometric functions, we begin with linear functions. Representing linear functions on a coordinate grid demonstrates how symmetry and measuring aid in locating lines in space. Slope or gradient is another comparison-of-quantities,  $\frac{\text{rise}}{\text{run}}$ . In the next section, we will use the comparison-of-quantities approach and symmetry to describe linear functions and trigonometric properties within the unit circle. These contexts each share ratio, symmetry, and location in space.

We use linear functions as a way to connect the same set of principles to algebraic thinking as we place a line in a coordinate grid. This combines movement, orientation, and algebra in a quadrant system. The ratio  $\frac{\text{rise}}{\text{run}}$  contains two parts of a right triangle, specifically the sides adjacent to the right angle. If you want to measure the distance along the line segment and if you want to understand the slope, you need to understand rise over run.

In the following, we provide three examples of a linear function:

- (a) the parent function  $f(x) = x$ ,
- (b) the reflected function  $f(x) = -x$ , and
- (c) a shifted function  $f(x) = mx + b$ .

These examples allow us to explore the ratio of rise over run, symmetric movements, translations, reflections, and rotations using the measuring-as-comparison approach.

The parent linear function,  $f(x) = x$ , passes through the orthogonal center, the same center that we repeatedly used when constructing a variety of geometric shapes, most importantly the center of the material in which a square was to be constructed, as well as all the other planar shapes previously described. In this case, the chosen path will pass through the orthogonal center  $(0, 0)$  and move halfway between Above/North/ $y$ -axis and Side/East/ $x$ -axis.

This path is halfway between W and S, passing through the orthogonal center and halfway between E and N. In other words,  $\frac{\text{rise}}{\text{run}} = 1$ , hence forming a  $45^\circ$  angle with the  $x$ -axis.

In Figure 28, the physical representation of length shows that for every rise of 1 length there is an equal run of 1. This represents a positive slope based on the convention of positive numbers, describing motion on both the  $x$ -axis to the right (E) and the  $y$ -axis up (N). The reflected function,  $f(x) = -x$ , also shown in Figure 28, creates a mirror image reflected in the  $y$ -axis, or a rotation around the center, both resulting in a change in orientation and direction. For every point on the blue line (parent function), there is a reflected point on the red line, showing the reflection is across the  $x$ -axis. Notice the similarity to Raphael Jimmy's non-numeric square construction shown in Figures 19(c) and 19(d), and how the latter establishes a foundation for this parent function.

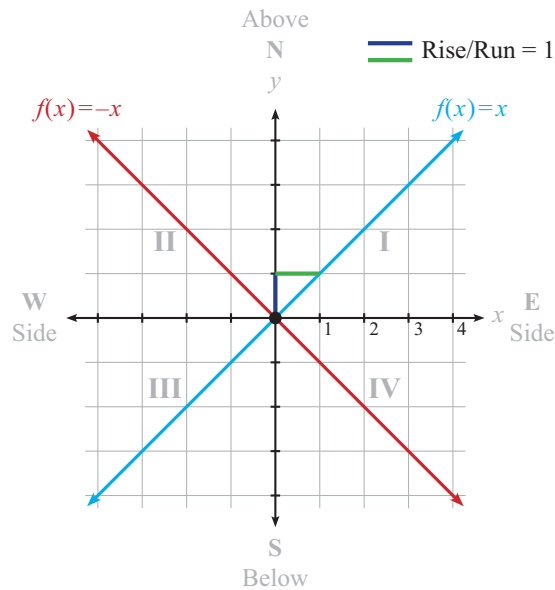

Figure 28: Parent linear function and reflection imposed on the coordinate grid and the Yupiaq spatial system.

Similarly, for the general linear function  $f(x) = mx + b$ , where  $m = \text{rise/run}$  or the gradient, and  $b$  is the  $y$ -intercept, the path of the line can be constructed from symmetry, measuring, and comparison-of-quantities.

In the example shown in Figure 29,  $f(x) = 2x + 3$ , rise over run equals  $2/1$  and the  $y$ -intercept is  $3$ , thus varying the location and orientation of the path, again as governed by the rise over run ratio of  $2/1$  (comparison-of-quantities) and symmetry. The parent function is translated from the orthogonal center up to  $+3$  on the  $y$ -axis until it passes through  $y = 3$ .

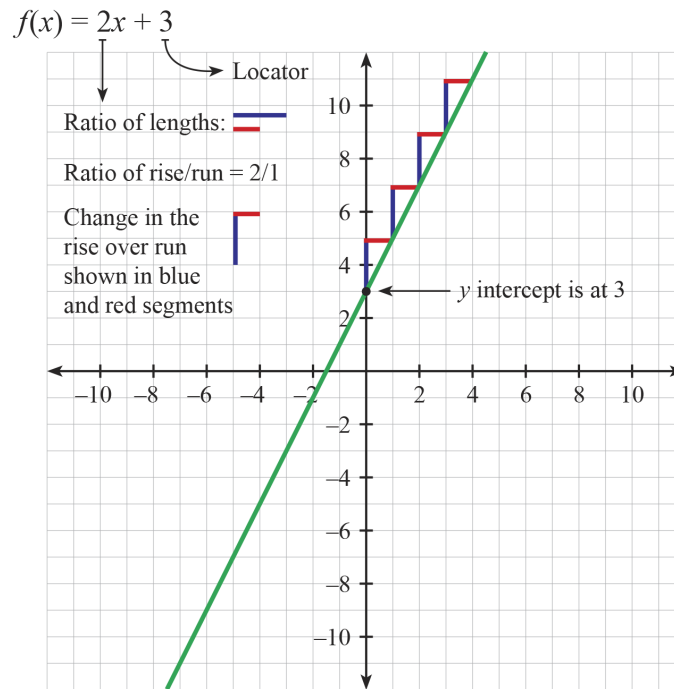

Figure 29: Applying comparison-of-quantities to a linear function using symmetry and the comparison-of-quantities approach.

Transformations of linear functions establish a pattern for applying the comparison-of-quantities approach with symmetry, measuring, halving, and center. This basic pattern supports explorations of more complex problems, and is the same pattern we have established from the beginning, locating position and number using a symmetric structure. Before engaging in trigonometric functions through the development of the unit circle, we have one last concept to investigate, that of  $\pi$ , yet again through the same pattern of thinking.

## 6. Pi and the Unit Circle, Orthogonal Coordinate System, and Trigonometric Functions

Just as we explored the irrational numbers  $\sqrt{2}$  and  $\sqrt{3}$  through the comparison-of-quantities approach, we can also explore an approximation of  $\pi$ , which we proceed to do in this section. This transcendental number<sup>8</sup> will be essential for the development of the unit circle and for understanding trigonometric functions by connecting space, unit, location, measurement, and our familiar constructed accessible shapes.

Pi,  $\pi$ , is the result of the comparison of two quantities: the length of the circumference of a circle and the length of its diameter. Figure 30 shows the relationship of a circle's circumference to its diameter, resulting in an approximation of  $\pi$ . This approach provides students with additional introductory experiences with numbers that are real but not rational.

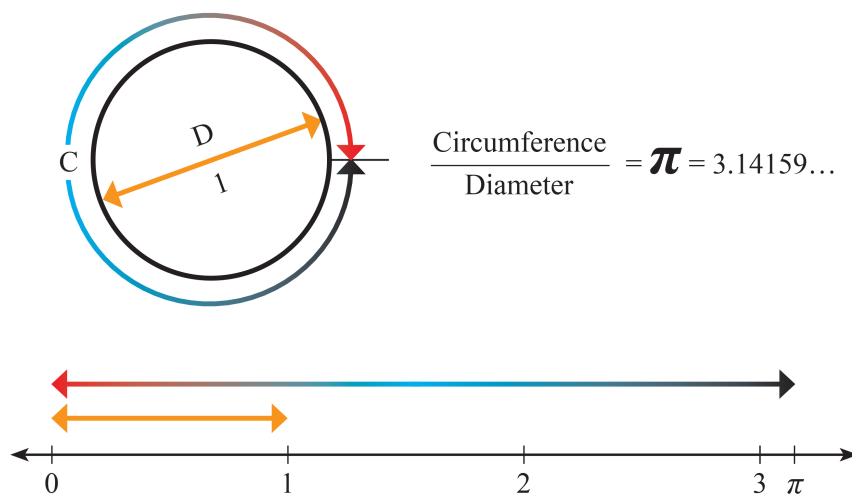

Figure 30: Pi,  $\pi$ , is found by comparing the circumference of a circle to its diameter, placing these lengths on a number line.

<sup>8</sup> When Dora Andrew-Ihrke went through this process to compare the circumference to the diameter, she used her folding algorithm to determine what was left over after 3. Once she reached a point, she said, “it’s an ugly number.” After turning off the video she said, “first time I couldn’t measure!”

### 6.1. The Unit Circle

We know the formula  $\text{Circumference} = d \cdot \pi$ , or  $C = 2\pi r$ . Combining this information with our previous knowledge, we can construct a circle with radius 1, called a *unit circle*, and begin to use it to measure distance, angle, location, and orientation in a complementary representation to the orthogonal quadrant system. Figure 31 uses the representation and language that we have used throughout to reinforce its similarity to the embodied orientation system.

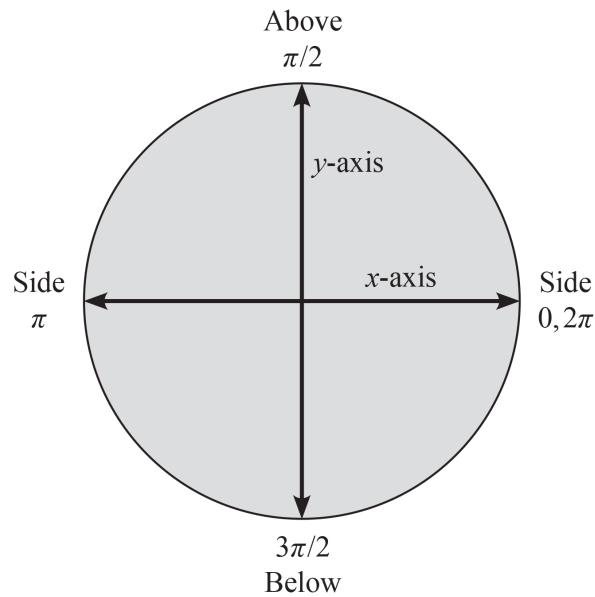

Figure 31: Establishing a unit circle connected to the Yupiaq spatial system.

By mathematical convention, movement around the center is in a counter-clockwise direction, and we label an angle of zero degrees ( $0^\circ$ ) in the direction of the positive  $x$ -axis. We label the associated point as  $x$  is 1 and  $y$  is 0, thus the ordered pair  $(1, 0)$ , as the circle has a radius of 1. Looking at angular motion and symmetry, the degree of  $\theta$  establishes the direction within the unit circle and is associated with a location on the circle. Once again, the paired opposites  $(1, 0)$ ,  $(-1, 0)$ , and  $(0, 1)$ ,  $(0, -1)$  are reflected in their numeric location, and generated by angular motion. Following common practice, we label the angle that falls on the positive  $y$ -axis as  $90^\circ$  or  $\pi/2$ , followed by  $180^\circ$  or  $\pi$ ,  $270^\circ$  or  $3\pi/2$ , and  $360^\circ$  or  $2\pi$ , which results in the same location as angle  $0^\circ$ .

This enables us to represent  $\pi$ , the ratio  $C/d$ , on a number line, at first using five specific locations:  $0$ ,  $\pi/2$ ,  $\pi$ ,  $3\pi/2$ , and  $2\pi$ . This approach also shows explicitly how the angle measures in degrees can be converted to radians by using the equality  $360^\circ = 2\pi$ .

Now that the four references are established, we can consider in between angles, just as some Yupiaq elders create more partitions to produce in between winds. By continuing symmetric “folding”, we can create as many positions on the unit circle as we want. Focusing on just the first quadrant, we see in Figure 32 a further refinement of the unit circle, including angles  $\theta$  reflected in angle increments of  $30^\circ$  and  $45^\circ$ , angles that are accessible through the geometric shapes we previously constructed. Note that the angles are the same as those found in the scaled triangles shown in Figures 25 and 27 with the hypotenuse of length 1.

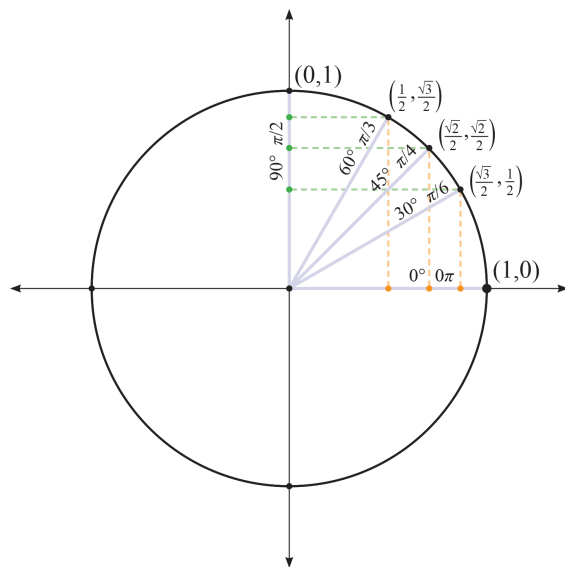

Figure 32: Additional angles that are accessible due to the triangles formed by them on the unit circle.

Through symmetry, reflections, and corresponding angles, the comparable angles in quadrants II, III, and IV are easily identified and accessible (Figure 33). All of the necessary information is contained in this one representation, which brings together location, movement, space, triangles, ratios, irrational numbers,  $\pi$ , positive numbers, negative numbers through symmetry, comparison-of-quantities, measuring, center, halving, and verifying.

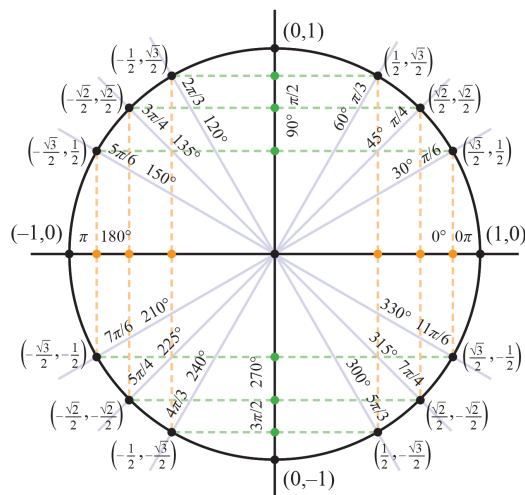

Figure 33: Representation of the unit circle, angles in degrees and radians, and locations marked in the  $(x, y)$  coordinate system.

In summary, using symmetry, we identified and located all of the corresponding angles and points around the unit circle, given what was known from Quadrant I. We used the unit circle to focus on various relationships between angles, locations, and distances. If we stay in this orientation, we can continue to investigate additional angles; however, if we change our focus to consider just the change in  $x$  or  $y$  values in relationship to the change in angles, then we move into the concepts of trigonometric functions by using the same approach and patterns we've used since beginning with position and number.

## 6.2. Trigonometry and Trigonometric Functions

We already know the relationships within the  $30^\circ$ - $60^\circ$ - $90^\circ$  triangle and the  $45^\circ$ - $45^\circ$ - $90^\circ$  triangle. This understanding has allowed us to construct and derive the square root of 3 and the square root of 2 by comparing lengths and using Pythagoras' theorem. In Figure 34, we provide the definition of the ratios of side lengths on any right triangle. By definition, the cosine of the angle is the ratio of the adjacent side length to the length of the hypotenuse, whereas the sine of the angle is the ratio of the opposite side length to the length of the hypotenuse. This definition provides a static representation, an anchor to view these relationships.

**Basic Trigonometric Relationships:  
Comparison of Quantities Perspective**

$$\cos \theta = \frac{\text{adjacent}}{\text{hypotenuse}}$$

$$\sin \theta = \frac{\text{opposite}}{\text{hypotenuse}}$$

$$\tan \theta = \frac{\text{opposite}}{\text{adjacent}}$$

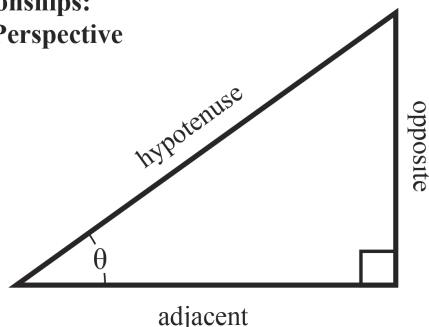

Figure 34: Basic trigonometric relationships presented from a comparison-of-quantities perspective.

We now move to a more dynamic view of the trigonometric relationships by considering angular motion and the related change in ratios<sup>9</sup> for trigonometric functions. In the unit circle, imposing a generic right triangle once again, we can view any point on the circle as an ordered pair  $(x, y)$  or  $(\cos \theta, \sin \theta)$ , since the hypotenuse is length of 1 as shown in Figure 35.

We focus now on the location of points on the grid for the angles that fall along the  $x$ -axis and  $y$ -axis. The ordered pair  $(1, 0)$  relates to the location on the circumference when the angle is  $0^\circ$ . When we focus on the cosine function, we switch the coordinate system where the horizontal axis represents the angle of rotation  $\theta$ , and vertical axis represent  $\cos \theta$ , producing the ordered pair  $(\theta, \cos \theta)$ . The horizontal axis now becomes a number line showing the angle values, as in Figure 36.<sup>10</sup>

Although it looks like the same  $xy$ -coordinate grid we obtained in Section 5 when we were combining two different relationships (linear and ratio), the representation we have now arrived at is of an oscillating function.

<sup>9</sup> Although it appears that we have moved from Indigenous Knowledge, in fact, we have identified some correlates of angular motion and related changes in ratios to practical activities of Yupiaq seamstresses. Dora Andrew-Ihrke demonstrated in detail how she visualizes the processes of making a neck opening while producing a *qaspeq* (a woman's garment).

<sup>10</sup> Note that if we were to use intervals of  $15^\circ$  (or  $\pi/12$ ), this  $\theta$  number line would show evenly distributed points. But since the cosine and sine of  $15^\circ$  is not as accessible as those shown, we do not include them.



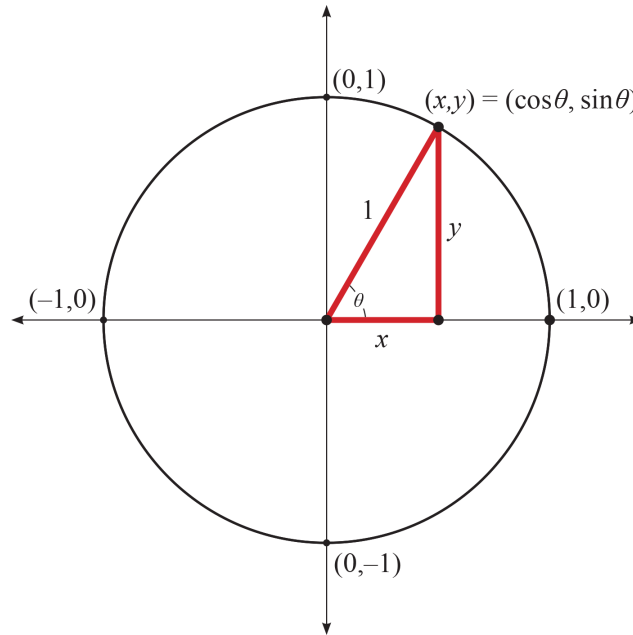
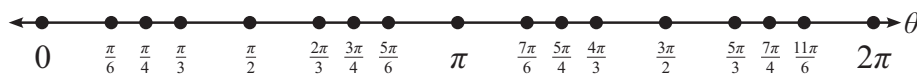
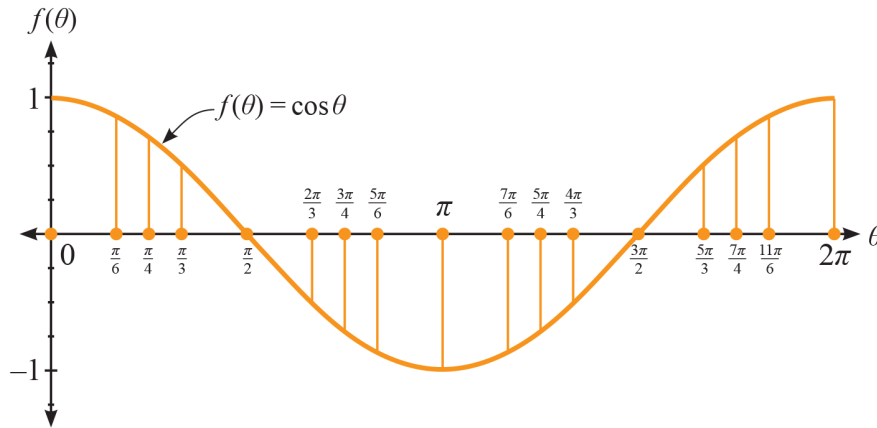

Figure 35: Two definitions of the location of a point on the circle.

The cosine function in Figure 37 shows the  $x$  values of each point on the unit circle within Figure 33 as the angle increases. The vertical lines are the same length as  $x$  values from the unit circle, but in a new representation. The dynamic focus is on the continuous change in ratio (adjacent/hypotenuse) with respect to the related continuous change in angle  $\theta$ . Theoretically, these functions continue in both directions indefinitely, depending on whether we rotate clockwise or counterclockwise.

The sine function in Figure 38 can be represented in a similar way by considering  $r$ , the  $y$  values of each point on the unit circle with respect to the angle. The green lines are the same length as the  $y$  values from the unit circle for the particular angle. Representations of cosine and sine generate symmetric wave-like curves, which are translations of each other.

Figure 36: Number line using angle measurement in relation to  $\pi$ .

Figure 37: Representation of cosine function with respect to  $\theta$ .

These two functions are the basic trigonometric functions from which all other trigonometric functions can be defined.

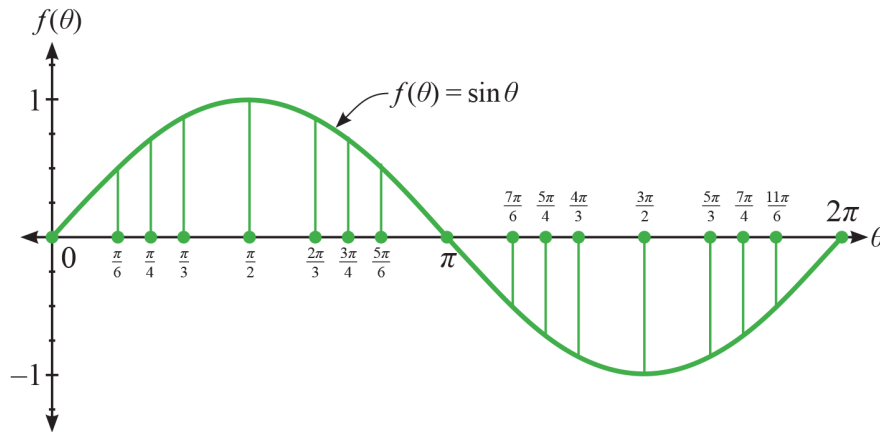
Figure 38: Representation of sine function with respect to  $\theta$ .

In these trigonometric functions, the fundamental symmetric structure is retained, and each graph can be “folded in half” to see that pattern. Further, translations and other symmetries previously discussed work similarly and are accessible by using the same basic patterns presented. In particular, symmetry and measuring from the unit circle provide the foundation for understanding a generic trigonometric function.

## 7. Discussion

The approach to symmetry and measuring described in this paper attempts to tap into the ways in which humans perceive symmetry and use symmetry to construct tools, navigate, orient, measure, create art and music, and perceive beauty. In a mathematics context, the regularity of symmetry and its many uses provides a potentially systematic and beautiful way to explore and learn about mathematical relationships. Although there is increasing interest in the role that symmetry can play in the teaching of positive and negative integers and number lines, little has been done to tap into the powerful and generative ways that symmetry/measuring can be used to teach the foundations of mathematical thinking in a cohesive way.

We believe we have presented a credible case for the power of including symmetry and measuring as a way to teach the foundations of mathematical thinking. This paper presents one way, not necessarily the only way or the best way, in which symmetry, measuring as a comparison-of-quantities, center, halving and doubling, and verification can establish productive mathematical ways of thinking and teaching. This potentially elegant and efficient approach to mathematics takes advantage of the human ability to perceive and construct through symmetry and its dynamic relationship to measuring.

We approach symmetry and measuring, initially, from mostly non-numeric comparison and embodied context situated in the everyday activities of Yupiaq and other Indigenous Knowledge holders. This approach highlights the power of symmetry and measuring, showing its potential to generalize to numbers, rational and irrational, to geometry and functions, as well as to trigonometry and various forms of representations. As reflected in the paper, beginning with the human body, symmetry and measuring provide a cohesive thread to often unconnected topics (positive and negative integers, rational and irrational numbers, and trigonometric functions) through constructing number line representations. Although this method reflects a culturally specific approach, such as the Yupiaq counting system, it simultaneously reflects universal aspects of symmetry and measuring and real-world aspects of orientation, movement, direction, and space. We establish a consistent and recurring symmetric structure and process revolving and oriented around the “center of everything”, forming a flexible coordinate system and flexible and dynamic uses of number line representations.

We also show how the dynamic relationship between symmetry and measuring brings together seemingly unrelated topics such as comparing lengths, establishing relative scales, and exploring number relations, place value, geometrical constructions, and geometrical similarity.

Symmetry and measuring provide a heuristic for tackling complex and even ugly problems by transforming them into accessible, beautiful shapes and patterns that may well be more manageable. In this paper we use the comparison-of-quantities approach to first consider the ratio relationships between length  $A$  and length  $B$  to investigate embodied numbers and access geometric shapes, and then we use it to explore irrational and transcendental numbers. We also use the comparison-of-quantities approach to investigate linear functions and slope and to extend that understanding to trigonometric functions by comparing the ratio of the side lengths to the change in angle, producing yet another beautiful pattern.

Although this approach may seem obvious to mathematicians, it is not how we teach school mathematics and use symmetry and measuring in the United States.

By using this cohesive, integrative, and generative approach we connect seemingly unconnected concepts across strands of mathematics. If students are provided an opportunity to learn in this way, the method may build connections and potentially deepen their mathematical understanding within and across mathematics strands. Although we have not emphasized this aspect of our method in this paper, this approach also supports ways for students to investigate conjecturing and problem solving. We also believe furthermore that our approach has the potential to remove the fear and boredom of mathematics, which we often hear about from teachers and students alike.

We recommend collaborative research between mathematics educators, developmental psychologists, cultural anthropologists/ethnomathematicians, and cognitive neuroscientists. Given research across disciplines that asserts that symmetry, measuring, counting, and locating are found across cultural groups, and given that symmetry has been identified by neuropsychologists and developmental psychologists as being a hard-wired capacity of humans to perceive, encode, and create, such collaborative enterprises could coordinate lab-oriented micro-level research to tap into the brain's capacity for learning mathematics through more holistic approaches.

This recommendation aligns with two-themed ZDM issues on neuroscience research and mathematics education (for example see [16, 3]), which call for a more collaborative approach between the fundamental researchers and mathematics educators and teachers.

We encourage research methodology that taps into the cohesive and generative power of symmetry and measuring connecting topics, strands, and representations. Without such research we risk atomizing and trivializing symmetry and measuring, pushing them back to the margins of mathematics education. Studies that tap into different aspects of the power of symmetry, using the grand approach, similar to [14] and [9], would potentially begin to provide the fundamental basis for exploring the efficacy of symmetry and measuring as key, foundational, activity-based concepts in mathematics education.

The examples presented above are by no means exhaustive. Symmetry and measuring are central to other coordinate systems — polar, spherical, cylindrical — and other fields of mathematics. Even though we did restrict our exploration here in various ways, through the comparison-of-quantities, we were nonetheless able to access all subsets of the real number system (counting numbers, integers, ratios, and irrationals) and engage in aspects of number theory, investigate how numbers behave, and connect them to algebra and geometry. Imaginary numbers may not be accessible with our models, but through parallels to real numbers, once defined, can also be investigated. Similarly, symmetries and their classifications can lead to the field of group theory.

## **8. Conclusion**

Symmetry has been a central concept for the ancient philosopher mathematicians, for leading physicists, philosophers, and neuroscientists, and for Indigenous practitioners. Bilateral symmetry was already being used in artwork from Minoan culture around 1800-1600 B.C. Throughout history and across cultures around the world people have recognized its beauty, its dynamic relationship with asymmetries, and its theoretical or cohesive nature. Yet, symmetry in present-day school mathematics remains a simplistic and underrepresented idea. We strongly suggest that symmetry can play a far greater role in the development of students' understanding of mathematics. We believe that this paper has shown the breadth, depth, and consistency

with which symmetry and measuring can be applied as a dynamic, generative, and cohesive process that supports mathematics learning and teaching, starting in the primary grades. The illustrated examples in this paper connect aspects of numbers and operations, geometry, algebraic reasoning, measurement, and varied and versatile forms of representations. Certainly an approach like this deserves more consideration. We thank the Yupiaq and Carolinian elders for opening our eyes to what was invisible in plain sight. We encourage others to extend this work practically and theoretically as we conclude our work.<sup>11</sup>

**Acknowledgments and Disclaimers.** This work has been generously supported by a grant from the National Science Foundation, Anna Kerttula program officer, Arctic Social Sciences division. The grant entitled The Potential Contribution of Indigenous Knowledge to Teaching and Learning Mathematics, was funded from 2012–2018 (grant number 1203194). However, any opinions, findings, and conclusions or recommendations expressed in this material are those of the authors and do not necessarily reflect the views of the National Science Foundation. We acknowledge the enduring steadfast support and tireless work of the Yupiaq practitioner scholars and educators. We name Raphael and Vivian Jimmy and in particular Raphael's major contribution in identifying *qukaq* (the center of everything). This was accomplished in a collegial environment with Anuska Nanalook, Anecia and Mike Toyukak providing multiple examples of the importance of the center and symmetry in everyday activity. Walkie Charles provided linguistic insights and creativity along with Eva Evelyn Yanez who moved from participant to co-leader in connecting the dots assisted by Sassa Peterson. Dora Andrew-Ihrke provided countless examples and demonstrations to make this seemingly invisible concept abundantly clear. Evelyn, Sassa, Walkie, and Dora switched from Yupiaq to English taking concepts from the non-Yupiaq scholars and from the Yupiaq practitioner scholars into a meaningful context. We also acknowledge the contributions of practitioner scholars from the Carolinian Islands in particular Cal Hachibma, Yap State Department of Education, Miuty Nokar, Chuuk State Department of Education, Ali Haleyalur a master navigator, Yap Traditional Navigation Society. Knowledge shared between the Yupiaq and Carolinian Islanders strengthened the case for the importance of symmetry, measuring, and center as both groups realized that these concepts were hiding in plain sight. The Carolinian examples strengthened this work. We wish to acknowledge Victor Zinger, University of Alaska Fairbanks, Judy and Mel Olson, both retired from the University of Hawai'i at Mānoa for their stimulating discussions and work associated with this project, which helped us see mathematical and pedagogical connections to the concepts of symmetry, measuring, and center. Lastly, we acknowledge the work of our core staff Amy Topkok, project manager; Jumiah Johnson, for graphics; Keely Colby, for graphics and page layout; as well as Dixon Jones, for graphics, and Fran Pedersen for editing and proofing.

---

<sup>11</sup> Our grants have concluded, most of the elders have moved on, and we now pass the mantle to the next generation.

## References

- [1] Alkire, W. H., “Systems of measurement on Woleai Atoll, Caroline Islands”, *Anthropos*, Volume **65** Number 1/2 (1970), pages 1–73.
- [2] Alkire, W. H., “Concepts of order in Southeast Asia and Micronesia”, *Comparative Studies in Society and History*, Volume **14** Number 4 (1972), pages 484–493.
- [3] Ansari, D., and Lyons, I. M., “Cognitive neuroscience and mathematics learning: how far have we come? Where do we need to go?”, *ZDM*, Volume **48** Number 3 (2016), pages 379–383.
- [4] Aristotle, *Metaphysics*, in *The complete works of Aristotle: The revised Oxford translation* (Vol. 2), edited by J. Barnes (Princeton University Press, Princeton, 1972), pages 1552–1728.
- [5] Ball, D., “Halves, pieces, and twos: Constructing representational contexts in teaching fractions” (Craft paper 90-2), National Center for Research on Teacher Learning, East Lansing, MI, 1990. SuDoc ED 1.310/2:324226.
- [6] Barlow, H. B., and Reeves, B. C., “The versatility and absolute efficiency of detecting mirror symmetry in random dot displays”, *Vision Research*, Volume **19** Number 7 (1979), pages 783–793.
- [7] Bass, H., “Is the Real Number Line Something to Be Built, or Occupied?” in *The Legacy of Felix Klein*, edited by H.G. Weigand, W. McCallum, M. Menghini, M. Neubrand, and G. Schubring (Springer, Cham, 2019), pages 67–77.
- [8] Birkhoff, G. D., *Aesthetic measure*, Harvard University Press, Cambridge, MA, 1933.
- [9] Brousseau, G., *Theory of didactical situations in mathematics: Didactique des mathématiques, 1970–1990*, Springer Science & Business Media, New York, 2002.
- [10] Burch, B., *Reality’s mirror: Exploring the mathematics of symmetry*, John Wiley & Son, New York, 1989.

- [11] Case, R., Okamoto, Y., Griffin, S., McKeough, A., Bleiker, C., Henderson, B., Stephenson, K., Segler, R., and Keating, D., *The role of central conceptual structures in the development of children's thought*, Monographs of the Society for Research in Child Development, **61**(1/2) (1996), pages 1–295.
- [12] Cheng, K., and Newcombe, N. S., “Is there a geometric module for spatial orientation? Squaring theory and evidence”, *Psychonomic Bulletin & Review*, Volume **12** Number 1 (2005), pages 1–23.
- [13] Common Core State Standards Initiative, *Mathematics Standards*, 2010. Available at <http://www.corestandards.org/Math/>, last accessed on January 28, 2019.
- [14] Davydov, V. V., *Types of generalization in instruction: Logical and psychological problems in the structuring of school curricula*, National Council of Teachers of Mathematics, Reston, VA, 1990. (Original work published 1972).
- [15] Davydov, V. V., and Tsvetkovich, Z. H., “On the objective origin of the concept of fractions”, *Focus on Learning Problems in Mathematics*, Volume **13** Number 1 (1991), pages 13–64.
- [16] De Smedt, B., and Verschaffel, L., “Traveling down the road: from cognitive neuroscience to mathematics education ... and back”, *ZDM*, Volume **42** Number 6 (2010), pages 649–654.
- [17] Dorsey, J. O., “A study of Siouan cults”, in J. W. Powell (Ed.), *Eleventh Annual Report of the Bureau of Ethnology*, edited by J.W. Powell (Smithsonian Institution, Washington, D.C., 1894), pages 351–544.
- [18] Dougherty, B., and Slovin, H. “Generalized diagrams as a tool for young children's problem solving”, in *Proceedings of the 28th Annual Meeting of the International Group for the Psychology of Mathematics Education*, Vol. 2, edited by M. J. Hoines, and A. B. Fuglestad (Bergen University College, Bergen, Norway, 2004), pages 295–302).
- [19] Dreyfus, T., and Eisenberg, T. “On symmetry in school mathematics”, *Symmetry: Culture and Science*, Volume **9** Number 2–4 (1998), pages 189–197.



- [20] Driver, J. S., Baylis, G. C., and Rafal, R. D., “Preserved figure-ground segmentation and symmetry in a patient with neglect”, *Nature*, Volume **360** (1992), pages 73–75.
- [21] Durkheim, E., and Mauss, M. *Primitive classification*, University of Chicago Press, Chicago, IL, 1963. (Original work published 1902).
- [22] Euclid, *Book VII*, in *The thirteen books of the elements*, vol. 2, edited by T.L. Heath (Dover Publications, New York, 1956), pages 277–345.
- [23] Euclid, *Book X*, in *The thirteen books of the elements*, vol. 3, edited by T.L. Heath (Dover Publications, New York, 1956), pages 1–260.
- [24] François, K., *Politiek van de wiskunde: Een theoretisch-filosofisch traject over de verbondenheden van de wiskunde met het politieke, met een praktische toepassing op het wiskundeonderwijs*, VUBPRESS, Brussels, 2008.
- [25] Gallistel, C. R., *The organization of learning*, The MIT Press, Cambridge, MA, 1990.
- [26] Giurfa, M., Eichmann, B., and Menzel, R., “Symmetry perception in an insect”, *Nature*, Volume **382** (1996), pages 458–461.
- [27] Goodenough, W. H., *Native astronomy in the Central Carolines*, The University Museum, University of Pennsylvania, Philadelphia, PA, 1953.
- [28] Greenberg, M. J., *Euclidean and non-Euclidean geometries: Development and history* (3rd edition), W. H. Freeman, New York, 1993.
- [29] Gross, D. J., “The role of symmetry in fundamental physics”, *Proceedings of the National Academy of Sciences*, Volume **93** Number 25 (1996), pages 14256–14259.
- [30] Hargittai, I. and Hargittai, M., *Symmetry: A unifying concept*, Shelter Publications, Bolinas, CA, 1994.
- [31] Hawkins, T., “Non-Euclidean geometry and Weierstrassian mathematics: The background to Killing’s work on Lie algebras”, *Historia Mathematica*, Volume **7** Number 3 (1980), pages 289–342.

- [32] Jayakrishnan, L., “Inner global positioning system of brain”, *Millennium Zoology*, Volume **15** Number 1 (2014), pages 58-59.
- [33] Kisker, E., Lipka, J., Adams, B. L., Rickard, A., Andrew-Ihrke, D., Yanez, E., and Millard, A., “The potential of a culturally based supplemental mathematics curriculum to improve the mathematics performance of Alaska Native and other students”, *Journal for Research in Mathematics Education*, Volume **43** Number 1 (2012), pages 75–113.
- [34] Kline, M., *Mathematical thought: From ancient to modern times*, vol. 1, Oxford University Press, Oxford, 1990. (Original work published 1972).
- [35] Levi-Strauss, C., “Do Dual Organizations Exist?” in his *Structural Anthropology* (Basic Books, New York, 1963), pages 132–163.
- [36] Lipka, J., “Culturally negotiated schooling: Toward a Yup’ik mathematics”, *Journal of American Indian Education*, Volume **33** Number 3 (1994), pages 14–30.
- [37] Lipka, J. Andrew-Ihrke, D., Koester, D., Zinger, V., Olson, M., Yanez, E., and Rubinstein, D., “Indigenous knowledge provides an elegant way to teach the foundations of mathematics”, in *Proceedings of the 37th annual meeting of the North American chapter of the International Group for the Psychology of Mathematics Education*, edited by T. Bartell, K.N. Bieda, R.T. Putnam, K. Bradfield and H. Domingue (Michigan State University, East Lansing, MI, 2015), pages 2–18.
- [38] Lipka, J., Andrew-Ihrke, D., Nokar, M., Koester, D., Rubinstein, D., Charles, W., Yanez, E., Hachibma, C., and Jimmy, R., “Symmetry and halving: A way to teach mathematical foundations, based on the everyday knowledge of Yupiaq and Caroline Islanders”, *Cultural studies of science education*, forthcoming.
- [39] Lipka, J., Mohatt, G. V., and the Ciulistet Group, *Transforming the culture of schools: Yup’ik Eskimo examples*, Lawrence Erlbaum Associates, Mahwah, NJ, 1998.
- [40] Livio, M., *The equation that could not be solved: How mathematical genius discovered the language of symmetry*, Simon & Schuster, New York, 2006.

- [41] Lockhart, P., *Measurement*, The Belknap Press of Harvard University Press, Cambridge, MA, 2012.
- [42] McCrink, K., Spelke, E., Deheane, S., and Pica, P., “Non-symbolic halving in an Amazonian indigene group”, *Developmental Science*, Volume **16** Number 3 (2013), pages 451–462.
- [43] O’Keefe, J., “Spatial cells in the Hippocampal Formation”, PDF document, 2014. Available at the Nobel Prize website [https://www.nobelprize.org/nobel\\_prizes/medicine/laureates/2014/okeefe-lecture.pdf](https://www.nobelprize.org/nobel_prizes/medicine/laureates/2014/okeefe-lecture.pdf), last accessed on January 28, 2019.
- [44] Plato, *Timaeus*, in *The complete works, part 3: Late dialogues* [Kindle version], edited by B. Jowett (Titan Read, Copenhagen, 2018), pages 34b.
- [45] Pierce, D., “On commensurability and symmetry”, *Journal of Humanistic Mathematics*, Volume **7** Number 2 (2017), pages 90–148.
- [46] Radin, P., *The Social Organization of the Winnebago Indians, an Interpretation* (Canada Geological Survey Museum Bulletin Anthropological Series 5 Volume 10), Government Printing Bureau, Ottawa, 1915.
- [47] Rubinstein, D., “The social fabric: Micronesian textile patterns and social order”, in *Art in small-scale societies: Contemporary readings* (3rd edition), edited by R. Anderson and K. Field (Prentice Hall, Englewood, NJ, 1993), pages 70–83.
- [48] Saxe, G. B., and Shaughnessy, M. M., “Children’s interpretations of fractions on the number line”, paper presented at the meeting of the American Educational Research Association, New York, March 2008.
- [49] Saxe, G. B., Shaughnessy, M. M., Gearhart, M., and Haldar, L. C., “Coordinating numeric and linear units: Elementary students’ strategies for locating whole numbers on the number line”, *Mathematical Thinking and Learning*, Volume **15** Number 4 (2013), pages 235–258.
- [50] Schmittau, J., and Morris, A., “The development of algebra in the elementary mathematics curriculum of V.V. Davydov”, *The Mathematics Educator*, Volume **8** Number 1 (2004), pages 60–87.

- [51] Sophian, C., *The origins of mathematical knowledge in childhood*, Lawrence Erlbaum Associates, New York, 2008.
- [52] Struik, D. J., *A Concise History of Mathematics* (3rd edition), Dover Publications, New York, 1967. (Original work published 1948)
- [53] Sugito, S., “Construction, techniques, and traditional architectural knowledge on Elato Atoll, Caroline Islands”, *Senri Ethnological Studies*, Volume **21** (1987), pages 279–320.
- [54] Trkovska, D., “Felix Klein and his Erlanger Programm”, in *WDS’07 Proceedings of Contributed Papers: Part I – Mathematics and Computer Sciences*, edited by J. Safrankova and J. Pavlu (Matfyzpress, Prague, Czech Republic, 2007), pages 251–256.
- [55] Tsang, J. M., Blair, K. P., Bofferding, L., and Schwartz, D. L., “Learning to ‘see’ less than nothing: Putting perceptual skills to work for learning numerical structure”, *Cognition and Instruction*, Volume **33** Number 2 (2015), pages 154–197.
- [56] Venenciano, L., “Early curricular experiences with nonnumeric quantities, evidence of an enduring perspective”, *International Journal for Mathematics Teaching & Learning*, Volume **18** Number 2 (2017), pages 181–202.
- [57] Venenciano, L., Slovin, H., Zenigami, F., and Yagi, S., “Learning place value through a measurement context”, in *Conference Proceedings of The Twenty-third ICMI Study: primary mathematics study on whole numbers*, edited by X. H. Sun, B. Kaur and J. Novotna (University of Macau, Macau, China, 2015), pages 575–582.
- [58] Washburn, D., editor, *Embedded Symmetries: Natural and Cultural*, University of New Mexico Press, Albuquerque, NM, 2004.
- [59] Washburn, D. and Crowe, D., *Symmetries of culture: Theory and practice of plane pattern analysis*, University of Washington Press, Seattle, WA & London, England, 1998.
- [60] Weyl, H., *Symmetry*, Princeton University Press, Princeton, NJ, 1952.

- [61] Wilczek, F., *Quanta, Symmetry, and Topology*, talk given on September 24, 2010, at the Institute for Advanced Study, Princeton. Video available at <https://www.ias.edu/ideas/2010/wilczek-quanta-symmetry-topology>, last accessed on January 28, 2019.
- [62] Witherspoon, G., and Peterson, G., *Dynamic symmetry and holistic asymmetry in Navajo and western art and cosmology*, Peter Lang Publishing, New York, 1995.
- [63] Wynn, T., “Archaeology and cognitive evolution”, *Behavioral and Brain Sciences*, Volume **25** Number 3 (2002), pages 389–402.
- [64] Yaglom, I.M., *Felix Klein and Sophus Lie: Evolution of the idea of symmetry in the nineteenth century*, Birkhäuser, Boston, MA, 1988.